

RoHS



CUST INFORMATION.

PART NO.	DRAWING NO.	REV.
----------	-------------	------

NOTE:

1. MATERIAL:

1.1. INSULATION: NYLON 6T UL 94V-0 (BLACK)

1.2. CONTACT: SQ. 0.50mm BRASS

2. FINISH: GOLD FLASH PLATING

3. RoHS & HALOGEN-FREE COMPLIANCE

4. BILL OF PART NO.

20160203-XXHF-XX-RP

CIRCUITS: 06~45

REEL & TAPE PACKAGE

VOID CIRCUIT: BLANK(STANDARD)

△ E2: VOID PIN 1&2&4

5. FOR AVAILABILITY, DELIVERY & MOQ, CONTACT CKM

6. DIMENSIONAL

POS	A	B	POS	A	B
06	2.0	4.0	27	16.0	18.0
09	4.0	6.0	30	18.0	20.0
12	6.0	8.0	33	20.0	22.0
15	8.0	10.0	36	22.0	24.0
18	10.0	12.0	39	24.0	26.0
21	12.0	14.0	42	26.0	28.0
24	14.0	16.0	45	28.0	30.0

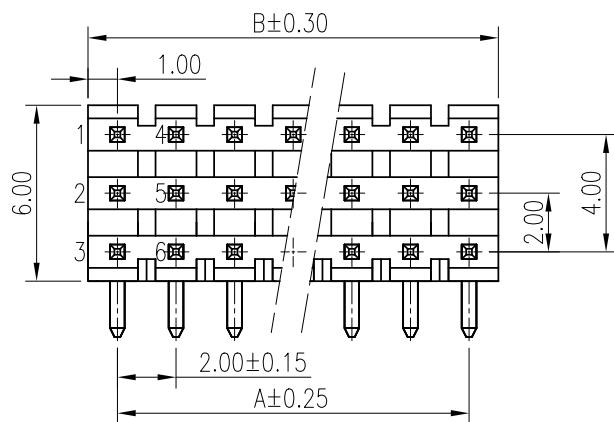

20160203-XXHF-RP

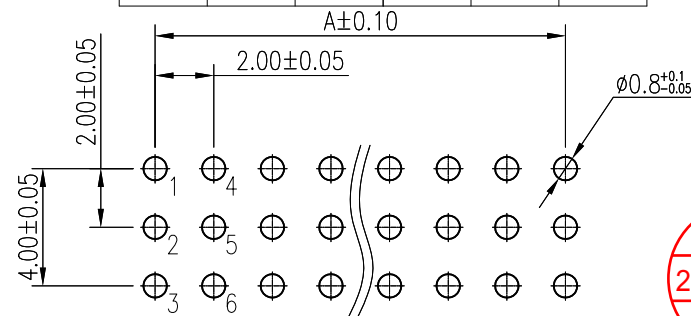
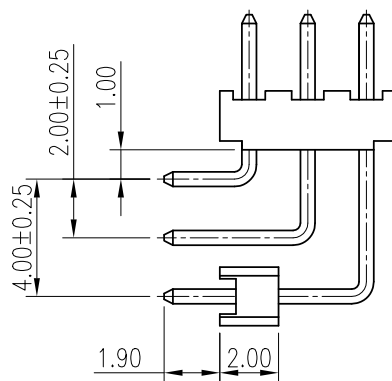
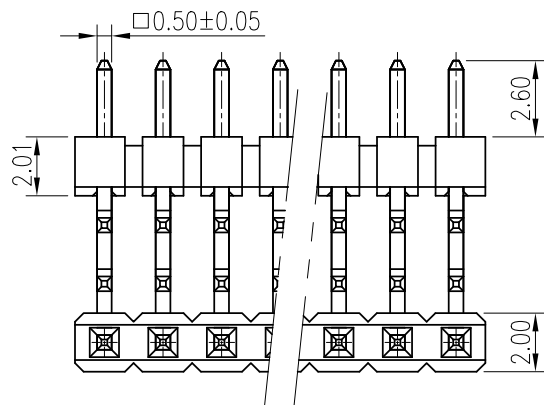
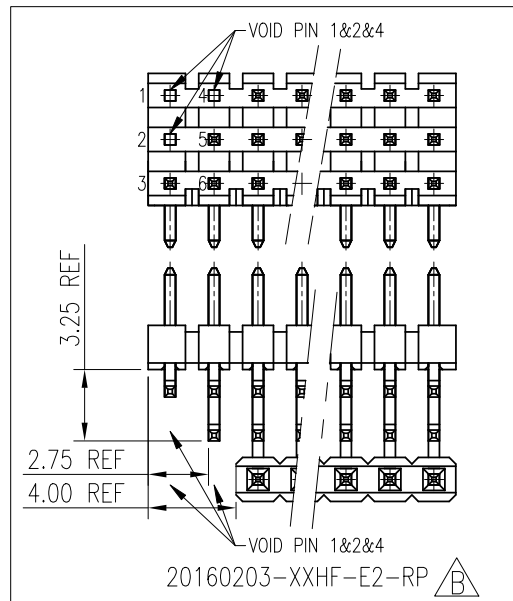

RECOMMEND PCB LAYOUT, TOLERANCE ±0.05

SUITABLE FOR PCB THK= 1.0~1.6MM



<b>TOLERANCE</b> X. X.XXX ±0.10 X.X ±0.30 X.XX ±0.20 Angular ±2°		<b>PART NO.</b> 20160203-XXHF-XX-RP		朝貴電子股份有限公司 CKM ELECTRONICS CO., LTD.	
		<b>DRAWING NO.</b> C-20160203-XXHF-XX-RP		<b>TITLE:</b> 2.0mm PITCH RIGHT ANGLE DIP TYPE TRIPLE ROWS PIN HEADER	
<b>DWG TYPE.</b> Customer Drawing		<b>APPROVED BY</b> Ivan.su 2023.03.01	<b>CHECKED BY</b> Jimmy Wang 2023.03.01	<b>DRAWN BY</b> Lance Cheng 2023.03.01	<b>PAGE</b> 1 OF 2  <b>SCALE</b> 4 : 1
				<b>REV.</b> B	

B	EC-23031457	ADD DRAWING	Lance Cheng	2023.03.01
A		NEW RELEASE	Jimmy Wang	2019.02.22
REV.	ECN NO	REVISION RECORD	DRAW	DATE

RoHS

HF

CUST INFORMATION.

PART NO.	DRAWING NO.	REV.
----------	-------------	------

A

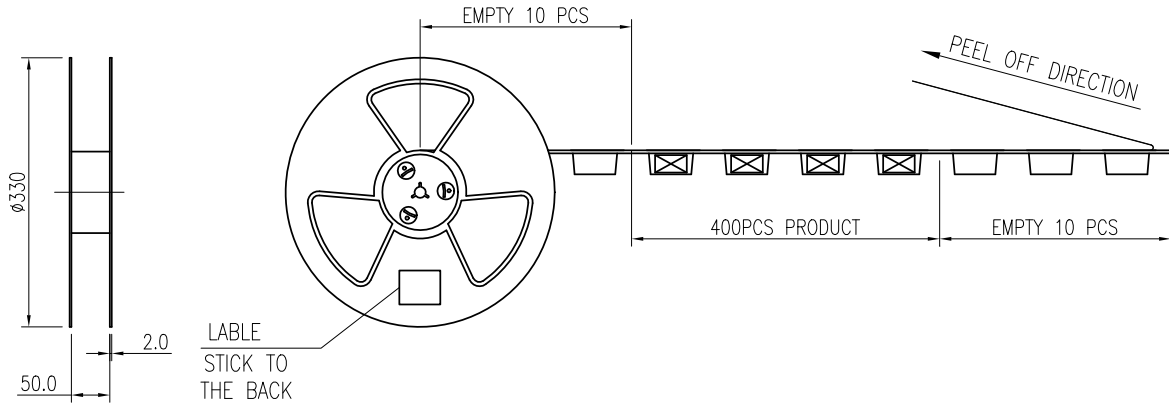

B

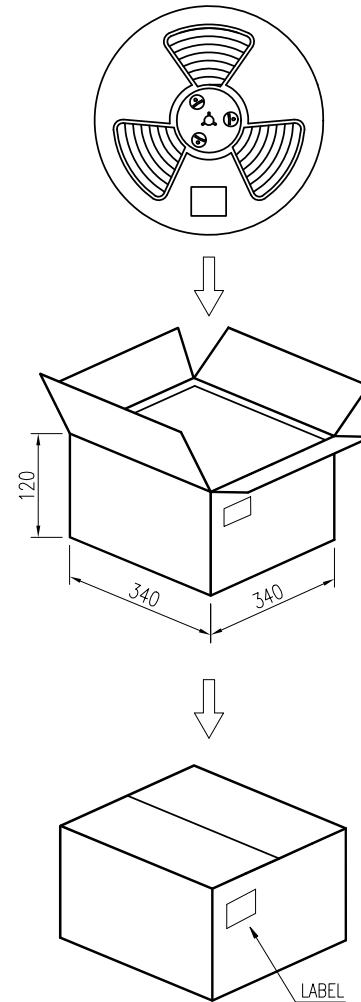

C

POS	PART NO.	PART NO.	A	PCS/REEL	PCS/CARTON
6	20160203-06HF-RP	20160203-06HF-E2-RP			
12	20160203-12HF-RP	20160203-12HF-E2-RP			
18	20160203-18HF-RP	20160203-18HF-E2-RP			
24	20160203-24HF-RP	20160203-24HF-E2-RP	28.1		
30	20160203-30HF-RP	20160203-30HF-E2-RP		400	800
36	20160203-36HF-RP	20160203-36HF-E2-RP			
42	20160203-42HF-RP	20160203-42HF-E2-RP			
9	20160203-09HF-RP	20160203-09HF-E2-RP			
15	20160203-15HF-RP	20160203-15HF-E2-RP			
21	20160203-21HF-RP	20160203-21HF-E2-RP	30.1		
27	20160203-27HF-RP	20160203-27HF-E2-RP			
33	20160203-33HF-RP	20160203-33HF-E2-RP			
39	20160203-39HF-RP	20160203-39HF-E2-RP			
45	20160203-45HF-RP	20160203-45HF-E2-RP			

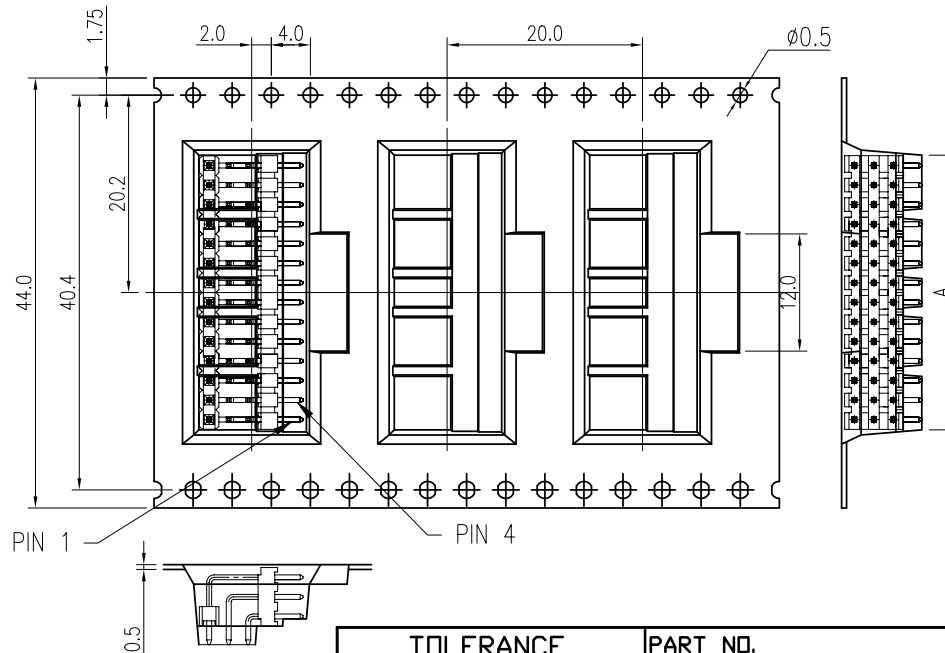

D

<b>TOLERANCE</b> X. X.XXX ±0.10 X.X ±0.30 X.XX ±0.20 Angular ±2°		<b>PART NO.</b> 20160203-XXHF-XX-RP		朝貴電子股份有限公司 CKM ELECTRONICS CO., LTD.	
<b>UNIT:</b> mm		<b>DRAWING NO.</b> C-20160203-XXHF-XX-RP		<b>TITLE:</b> 2.0mm PITCH RIGHT ANGLE DIP TYPE TRIPLE ROWS PIN HEADER	
<b>DWG TYPE.</b> Customer Drawing		<b>APPROVED BY</b> Ivan.su 2023.03.01	<b>CHECKED BY</b> Jimmy Wang 2023.03.01	<b>DRAWN BY</b> Lance Cheng 2023.03.01	<b>PAGE</b> 2 OF 2  <b>SCALE</b> 4 : 1
				<b>REV.</b> B	

B	EC-23031457	ADD DRAWING	Lance Cheng	2023.03.01
A		NEW RELEASE	Jimmy Wang	2019.02.22
REV.	ECN NO	REVISION RECORD	DRAW	DATE