

RoHS

HF

CUST INFORMATION.

PART NO.	DRAWING NO.	REV.
----------	-------------	------

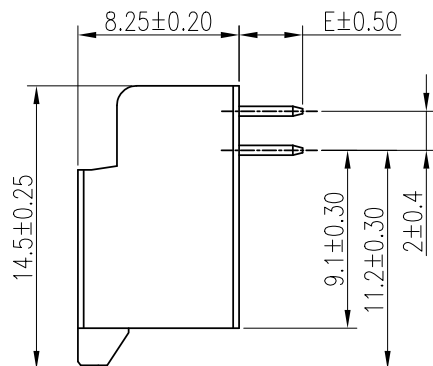
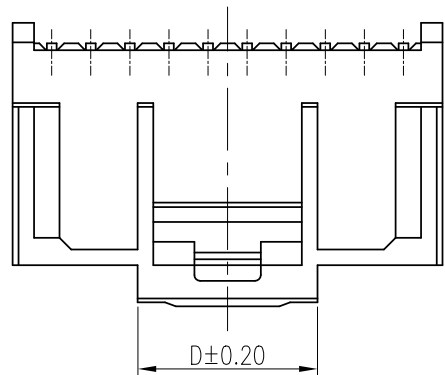

NOTE:

- MATERIAL:
  - INSULATOR:LCP UL 94V-0
  - CONTACT=SQ 0.50mm BRASS
- FINISH: TIN
- RoHS & HF COMPLIANCE
- BILL OF PART NO:

2021WR-XP-XX-XX-HF

No of CIRCITS:  PIN TAIL(DIM E)  
 10~40  BLANK: 3.20  
                    2.2 : 2.20mm

COLOR: BLANK(NATURAL) OR A=BLACK  
 FINISH: A=MATTE-TIN PLATING  
 B=BRIGHT-TIN PLATING

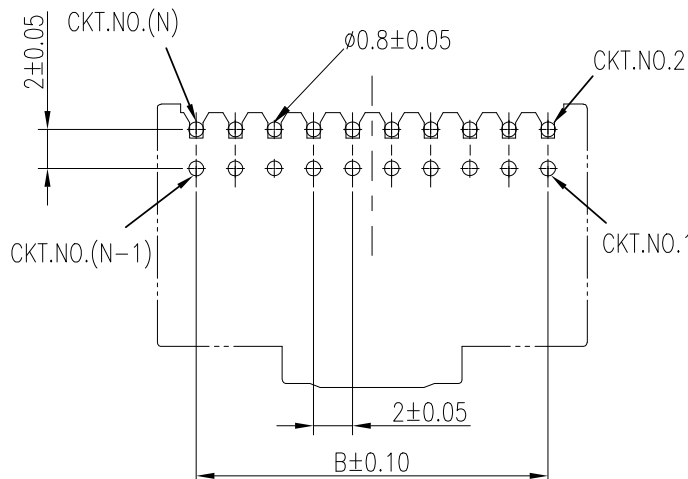
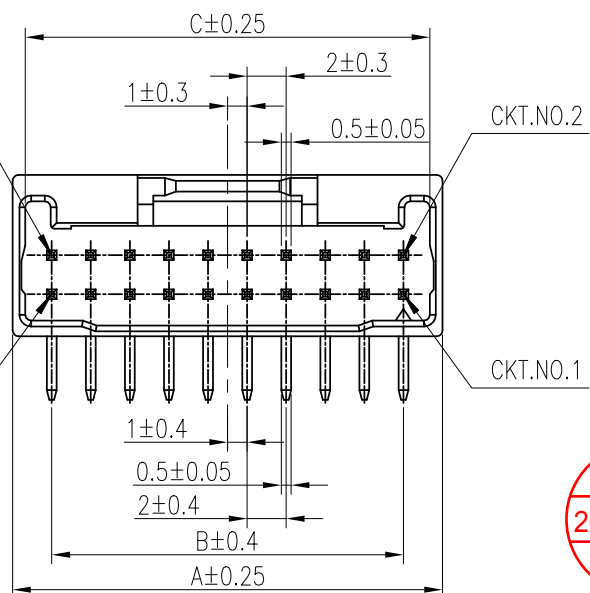

5. DIMENSIONAL

POS	A	B	C	D
40	42	38	40.7	9.2
38	40	36	38.7	9.2
36	38	34	36.7	9.2
34	36	32	34.7	9.2
32	34	30	32.7	9.2
30	32	28	30.7	9.2
28	30	26	28.7	9.2
26	28	24	26.7	9.2
24	26	22	24.7	9.2
22	24	20	22.7	9.2
20	22	18	20.7	9.2
18	20	16	18.7	9.2
16	18	14	16.7	9.2
14	16	12	14.7	9.2
12	14	10	12.7	9.2
10	12	8	10.7	7.3

RECOMMENDED P.C.BOARD  
 HOLE DIMENSION (T=1.2~1.6)  
 (MOUNTING SIDE)



<b>TOLERANCE</b>		<b>PART NO.</b>		<b>朝貴電子股份有限公司</b> <b>CKM ELECTRONICS CO., LTD.</b>	
X. ±0.50	X.XXX ±0.15	2021WR-XP-XX-XX-HF			
X.X ±0.35	Angular ±5°	<b>DRAWING NO.</b>		<b>TITLE: IGRID 2.0MM W/B DUAL DIP</b> <b>PLUG ASSY RA</b>	
X.XX ±0.25		C-2021WR-XP-XX-XX-HF			
<b>UNIT:</b> mm		<b>APPROVED BY</b>	<b>CHECKED BY</b>	<b>DRAWN BY</b>	<b>PAGE</b>
		Ivan Su 2022/07/11	Deliang Li 2022/07/11	Ryan 2022/07/11	1 OF 2
<b>DWG TYPE.</b>				<b>SCALE</b>	
Customer Drawing				4 : 1	A1

A1		RENEW THE DRAWING	Ryan	2022/07/11
A		NEW RELEASE	HEIMER	2021/01/08
<b>REV.</b>	<b>ECN NO</b>	<b>REVISION RECORD</b>	<b>DRAW</b>	<b>DATE</b>

RoHS

HF

CUST INFORMATION.

PART NO. DRAWING NO. REV.

6. PACKAGE DRAWING

CKM  
2023.08.22  
研发部

A

B

C

D

A

B

C

D

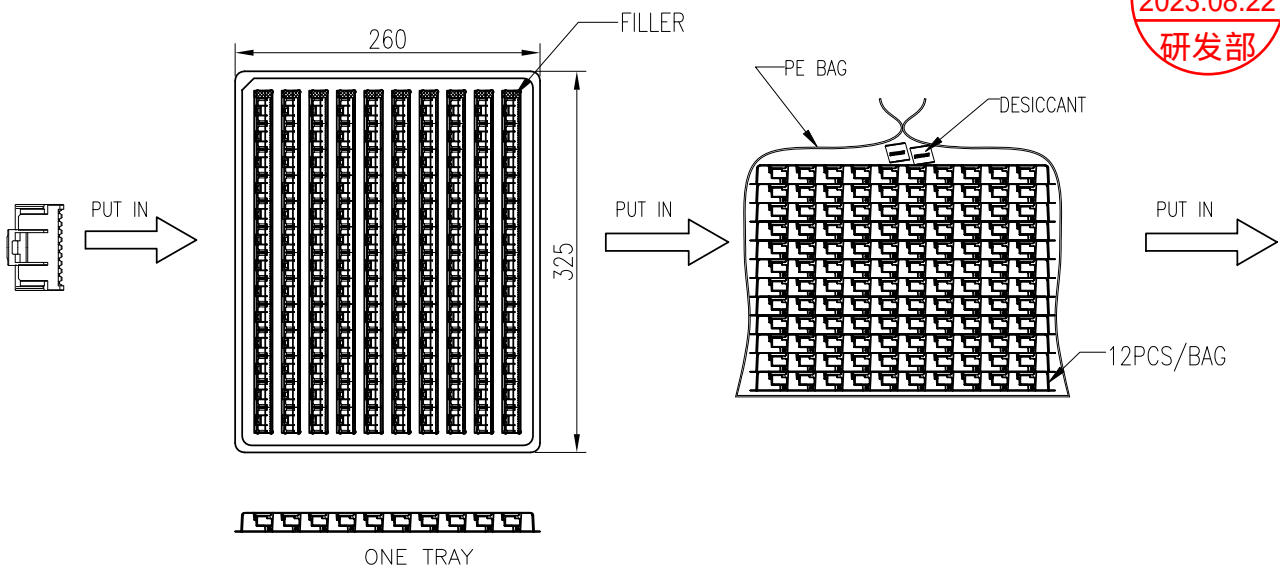

7. STANDARD PACKAGING QUANTITY

CKT. SIZE	PLASTIC TRAY (12 ROWS)	TRAYS	SHIPPING CARTON
	QTY. IN ONE TRAY(pcs)	NUMBER OF TRAYS	QUANTITY(pcs)
10	240	12	2880
12	200	12	2400
14	180	12	2160
16	160	12	1920
18	140	12	1680
20	130	12	1560
22	120	12	1440
24	110	12	1320
26	100	12	1200
28	90	12	1080
30	90	12	1080
32	80	12	960
34	80	12	960
36	70	12	840
38	70	12	840
40	60	12	720

A1		RENEW THE DRAWING	Ryan	2022/07/11
A		NEW RELEASE	HEIMER	2021/01/08
REV.	ECN NO	REVISION RECORD	DRAW	DATE

<b>TOLERANCE</b> X. ±0.50 X.XXX ±0.15 X.X ±0.35 X.XX ±0.25 Angular ±5°		<b>PART NO.</b> 2021WR-XP-XX-XX-HF		朝貴電子股份有限公司 CKM ELECTRONICS CO., LTD.	
UNIT: mm <b>DWG TYPE.</b> Customer Drawing		<b>DRAWING NO.</b> C-2021WR-XP-XX-XX-HF		<b>TITLE.</b> IGRID 2.0MM W/B DUAL DIP PLUG ASSY RA	
<b>APPROVED BY</b> Ivan Su 2022/07/11		<b>CHECKED BY</b> Deliang Li 2022/07/11		<b>DRAWN BY</b> Ryan 2022/07/11	
				<b>PAGE</b> 2 OF 2	
				<b>SCALE</b> 4 : 1	
				<b>REV.</b> A1	