

RoHS

HF

CUST INFORMATION.

PART NO. NA	DRAWING NO. NA	REV. NA
----------------	-------------------	------------

NOTE:

- MATERIAL:
 - INSULATION: NYLON 6T UL 94V-0
 - CONTACT: SQ 0.50mm BRASS
- FINISH: TIN/GOLD PLATING
- RoHS & HF COMPLIANCE
- BILL OF PART NO:

2015WV-XP-XX-XX-HF

POS: 2~16

HF=HALOGEN FREE

FINISH:

- A=MATTE-TIN PLATING
- B=BRIGHT-TIN PLATING
- C=GOLD FLASH PLATING

PIN LENGTH (SIZE D):

BLANK=3.0 /3.2=3.2 /3.5=3.5

COLOR: BLANK=NATURAL

A=BLACK OR B~Q

- FOR FINISH, COLOR, AVAILABILITY, DELIVERY & MOQ, CONTACT CKM
- DIMENSIONAL

POS	A	B	C
2	--	8.0	--
3	4.00	10.0	--
4	6.00	12.0	--
5	8.00	14.0	--
6	10.00	16.0	--
7	12.00	18.0	7.00
8	14.00	20.0	7.00
9	16.00	22.0	7.00
10	18.00	24.0	7.00
11	20.00	26.0	7.00
12	22.00	28.0	7.00
13	24.00	30.0	13.60
14	26.00	32.0	13.60
15	28.00	34.0	13.60
16	30.00	36.0	13.60

COLOR CODE	
BLANK	NATURAL
A	BLACK
B	BROWN
C	RED
D	ORANGE
E	YELLOW
F	GREEN
G	BLUE
H	PURPLE
J	GREY
K	WHITE
Q	BRICK RED

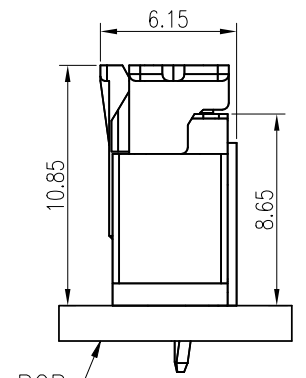
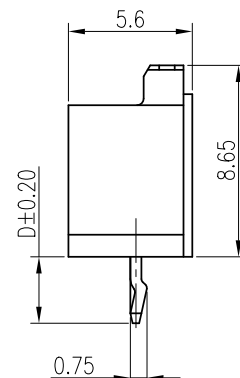
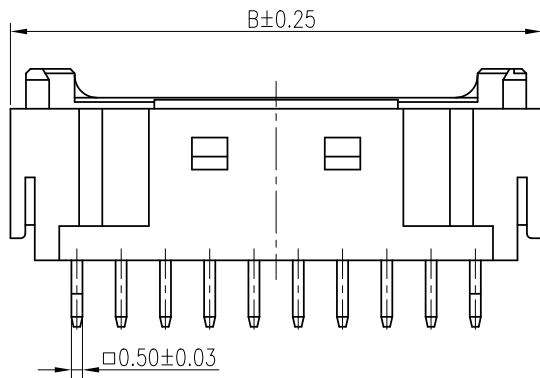
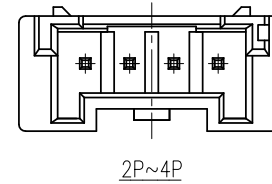
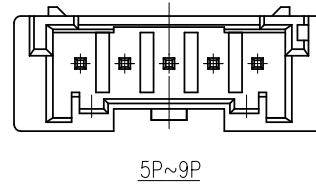
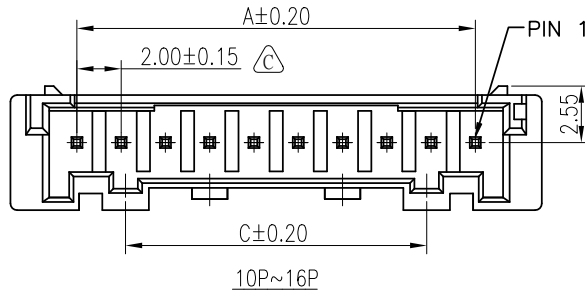

PCB ASSEMBLY LAYOUT TOP ENTRY TYPE

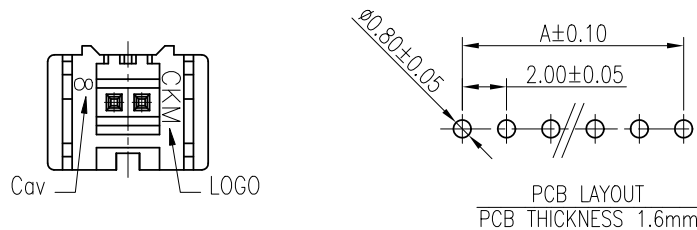

TOLERANCE	
X.	X.XXX ±0.10
X.X	±0.40
X.XX	±0.30
	Angular ±2°
	UNIT: mm
DWG TYPE. Customer Drawing	

PART NO. 2015WV-XP-XX-XX-HF
DRAWING NO. C-2015WV-XP-XX-XX-HF
APPROVED BY Ivan Su 2022/09/29

朝貴電子股份有限公司 CKM ELECTRONICS CO., LTD.
TITLE. 2.0mm PITCH VERTICAL DIP TYPE CONNECTOR
CHECKED BY Deliang Li 2022/09/29
DRAWN BY Ryan 2022/09/29
PAGE 1 OF 2
REV. D

D	EC-22091340	REVISE PIN LENGTH	Ryan	2022.09.29
C	EC-18010708	修正NOTE及修改公差	LZQ	2017.12.09
REV.	ECN NO	REVISION RECORD	DRAW	DATE

SCALE 3:1

RoHS

HF

CUST INFORMATION.

PART NO. NA	DRAWING NO. NA	REV. NA
----------------	-------------------	------------

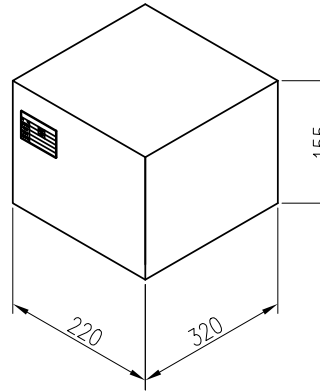
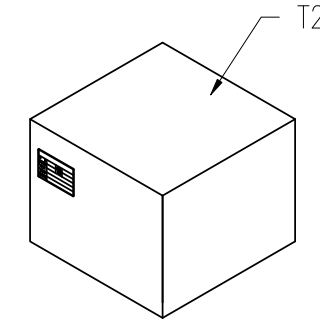
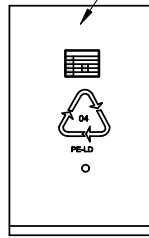
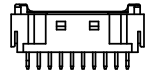

2 Inner BOX

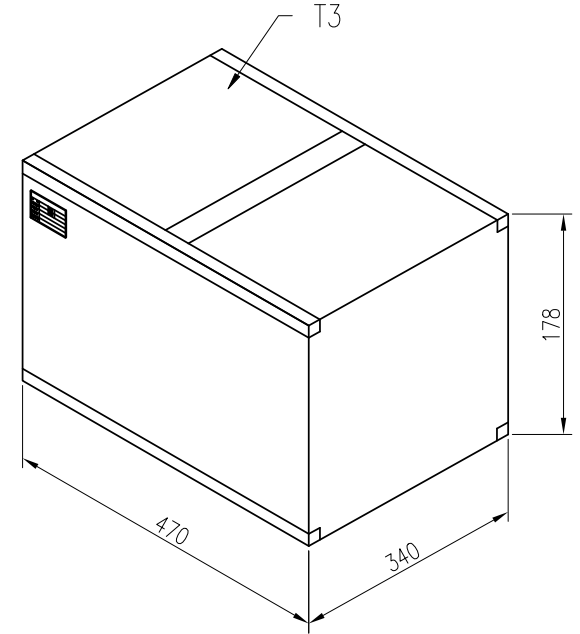

POS	BAG		Inner BOX-T2		Carton-T3		Weight Unit: (Kg)	
	PCS / BAG	PCS / Inner BOX	PCS / Carton	Net Weight	Gross Weight			
2	1000	18000	36000	11.52	12.86			
3	1000	13000	26000	9.62	10.96			
4	1000	9000	18000	9.92	9.30			
5	1000	7000	14000	6.16	7.50			
6	1000	6000	12000	5.40	6.74			
7	1000	6000	12000	6.84	8.18			
8	1000	5000	10000	7.68	9.02			
9	1000	5000	10000	7.20	8.54			
10	1000	4500	9000	7.56	8.90			
11	1000	4000	8000	7.12	8.46			
12	1000	3500	7000	6.72	8.06			
13	1000	3000	6000	6.06	7.40			
14	1000	3000	6000	6.36	7.70			
15	1000	2500	5000	5.60	6.94			
16	1000	2500	5000	5.85	7.19			

TOLERANCE		PART NO.		朝貴電子股份有限公司 CKM ELECTRONICS CO., LTD.	
X.	X.XXX ±0.10	2015WV-XP-XX-XX-HF			
X.X	±0.40	DRAWING NO.		TITLE.	
X.XX	±0.30	C-2015WV-XP-XX-XX-HF		2.0mm PITCH VERTICAL DIP TYPE CONNECTOR	
UNIT: mm		APPROVED BY	CHECKED BY	DRAWN BY	PAGE
		Ivan Su 2022/09/29	Deliang Li 2022/09/29	Ryan 2022/09/29	2 OF 2
DWG TYPE.				SCALE	
Customer Drawing				3 : 1	D

D	EC-22091340	REVISE PIN LENGTH	Ryan	2022.09.29
C	EC-18010708	修正NOTE及修改公差	LZQ	2017.12.09
REV.	ECN NO	REVISION RECORD	DRAW	DATE