

RoHS

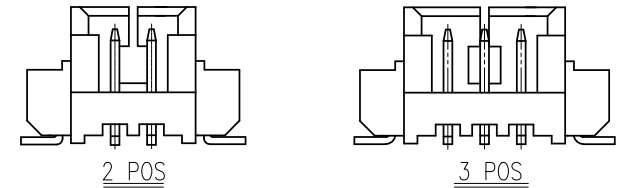
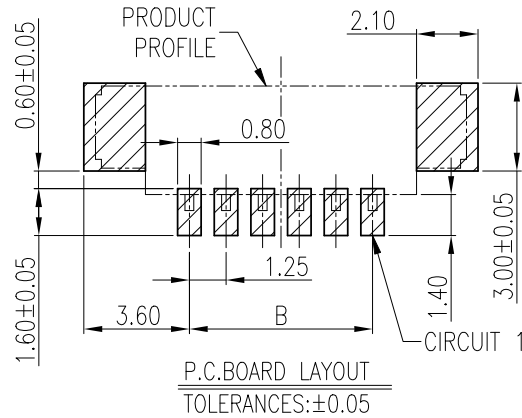
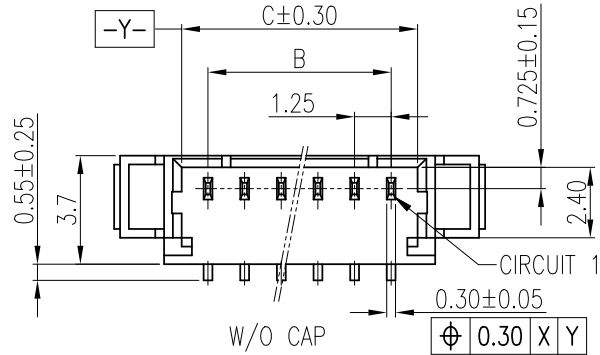

- MATERIAL SPECIFICATION:
 - 1.1 INSULATION : LCP UL 94V-0,COLOR:SEE P/N.
 - 1.2 CAP: LCP UL 94V-0,COLOR:NATURAL.
 - 1.3 CONTACT: THICK 0.30mm PHOSPHOR BRONZE.
 - 1.4 SOLDER TAB: THICK 0.25mm PHOSPHOR BRONZE.
- FINISH SPECIFICATION:
 - 2.1 CONTACT: MATTE TIN/GOLD PLATED.
 - 2.2 SOLDER TAB: MATTE TIN PLATED.
- BILL OF PART NO:
 - 1253WD-XP-XX-XX-HF

NO. OF CIRCUITS: 2~15

FINISH: A=MATTE TIN PLATED
C=GOLD FLASH PLATED

OPTION: BLANK=W/CAP
OR NC=W/O CAP

COLOR: BLANK(NATURAL)
OR A & G

4. FOR COLOR, AVAILABILITY, DELIVERY & MOQ, CONTACT CKM

5. DIMENSIONAL

POS	A	B	C	D
2	4.25		3.05	7.25
3	5.50	2.50	4.30	8.50
4	6.75	3.75	5.55	9.75
5	8.00	5.00	6.80	11.00
6	9.25	6.25	8.05	12.25
7	10.50	7.50	9.30	13.50
8	11.75	8.75	10.55	14.75
9	13.00	10.00	11.80	16.00
10	14.25	11.25	13.05	17.25
11	15.50	12.50	14.30	18.50
12	16.75	13.75	15.55	19.75
13	18.00	15.00	16.80	21.00
14	19.25	16.25	18.05	22.25
15	20.50	17.50	19.30	23.50

COLOR	CODE
BLANK	NATURAL
A	BLACK
G	BLUE

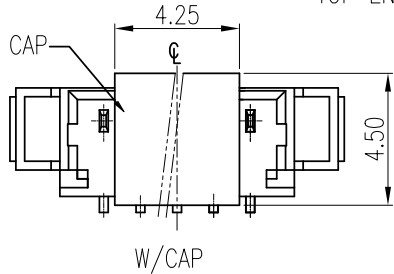
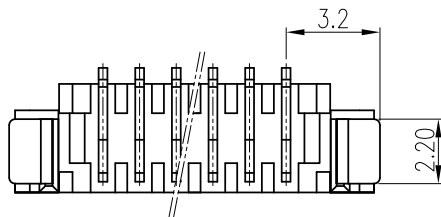
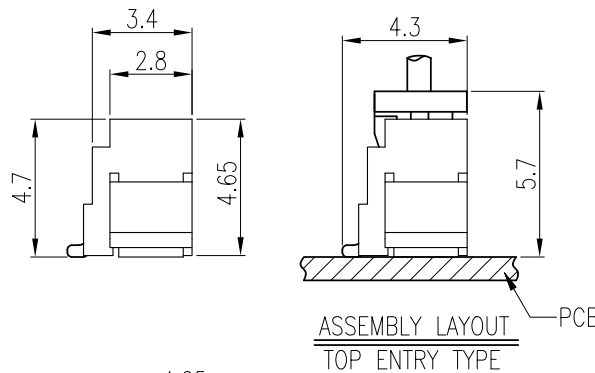
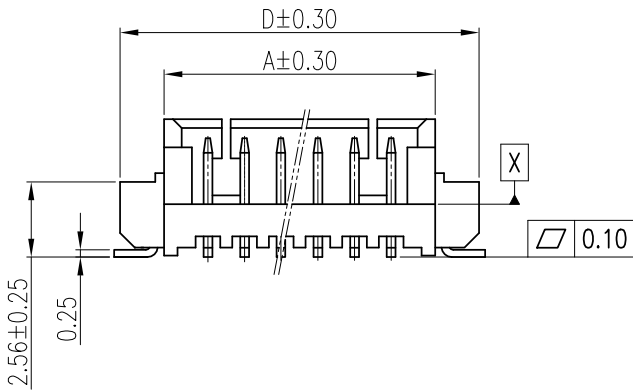

TOLERANCE		PART NO.		朝貴電子股份有限公司	
X.	X.XXX ±0.10	1253WD-XP-XX-XX-HF		CKM ELECTRONICS CO., LTD.	
X.X	±0.30	DRAWING NO.		DESCRIPTION	
X.XX	±0.20	C-125102X8-XXHF		CKM1253WD SERIES	
UNIT: mm		APPROVED BY		DRAWN BY	
DWG TYPE.		CHECKED BY		PAGE	
Customer Drawing		Ivan.su		1 OF 2	
		2022.06.20		SCALE	
		Sun.Lee		4 : 1	
		2022.06.20		REV.	
		Rock		F	
		2022.06.20			

REV.	ECN NO	REVISION RECORD	DRAW	DATE
F	EC-22060075	UPGRADE DESCRIPTION	Rock	2022.06.20
E	EC-22030061	UPGRADE DRAWING	Rock	2022.03.22

RoHS

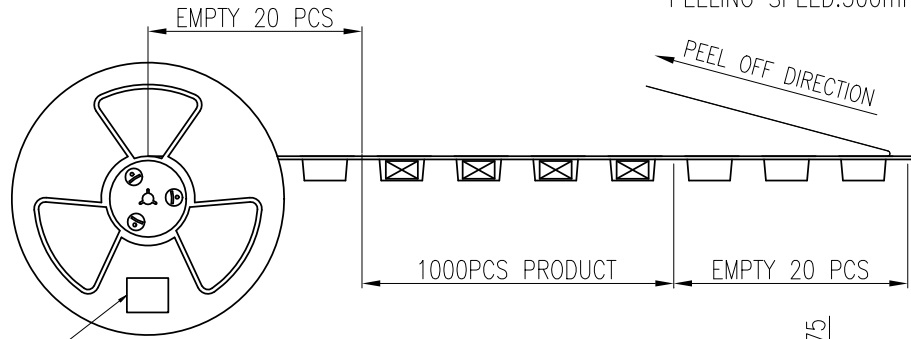
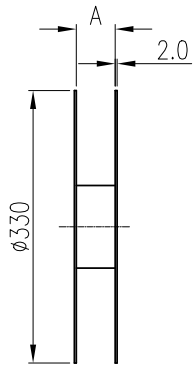

PEELING STRENGTH:10~130GF
PEELING SPEED:300mm/Min

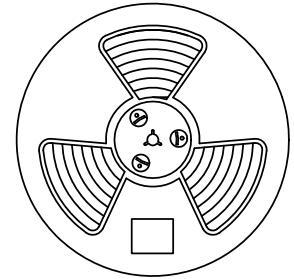

LABEL
STICK TO
THE BACK

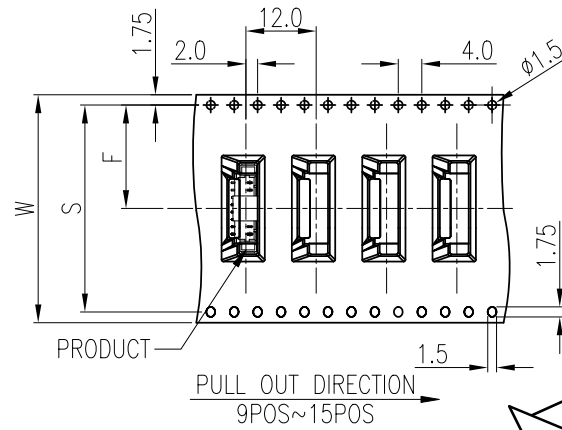
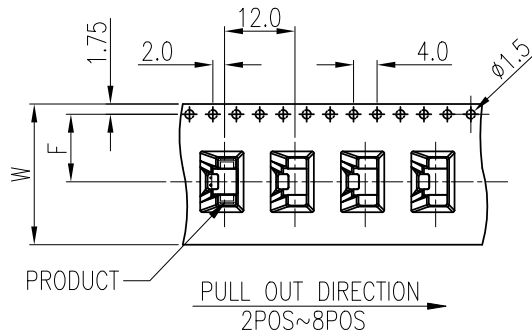
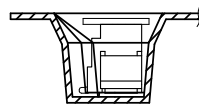

TABLE 1:

POS.	A	W	S	F	H
2~8	24.5	24.0		11.5	120
9~15	44.5	44.0	40.4	20.2	180

TABLE 2:

POS	PCS/REEL	PCS/CARTON
2~15	1000	3000



W/CAP

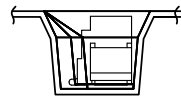

W/O CAP

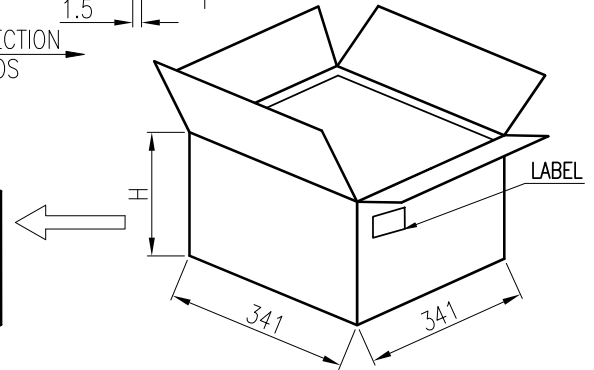
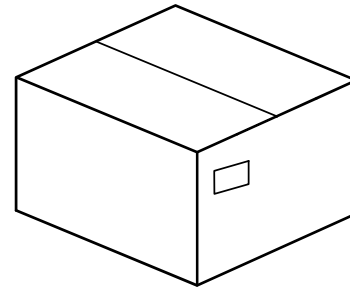

TOLERANCE		PART NO.		朝貴電子股份有限公司 CKM ELECTRONICS CO., LTD.	
X.	X.XXX ±0.10	1253WD-XP-XX-XX-HF		DESCRIPTION CKM1253WD SERIES 1.25mm PITCH V/T SMT TYPE WAFER PACKING	
X.X ±0.30		DRAWING NO. C-125102X8-XXHF			
X.XX ±0.20	Angular ±2°	APPROVED BY Ivan.su 2022.06.20		CHECKED BY Sun.Lee 2022.06.20	DRAWN BY Rock 2022.06.20
UNIT: mm		PAGE 2 OF 2		REV. F	
DWG TYPE. Customer Drawing		SCALE 4 : 1			

REV.	ECN NO	REVISION RECORD	DRAW	DATE
F	EC-22060075	UPGRADE DESCRIPTION	Rock	2022.06.20
E	EC-22030061	UPGRADE DRAWING	Rock	2022.03.22