

RoHS



CUST INFORMATION.

PART NO.	DRAWING NO.	REV.
----------	-------------	------

CKM
2023.07.10
研发部

NOTE:

- MATERIAL: NYLON 66 UL94 V-0
- RoHS COMPLIANCE
- BILL OF PART NO.
2503H-XP-X-XX
 - BLANK OR HF(HALOGEN FREE)
 - COLOR: BLANK=NATURAL
 - M=MILKY YELLOW
 - NO OF CIRCUITS: 2~18
- FOR COLOR, AVAILABILITY, DELIVERY & MOQ, CONTACT CKM
- DIMENSIONAL & ORDERING INFORMATION

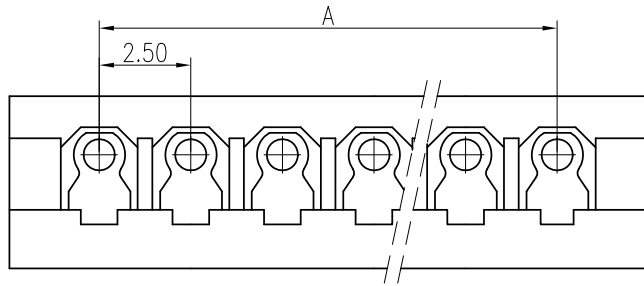

OLD P/N	NEW P/N	COLOR
25030101	2503H-XP-M-HF	MILKY YELLOW
25030102	2503H-XP-HF	NATURAL

POS	A	B	C
2	2.5	5.8	7.4
3	5.0	8.3	9.9
4	7.5	10.8	12.4
5	10.0	13.3	14.9
6	12.5	15.8	17.4
7	15.0	18.3	19.9
8	17.5	20.8	22.4
9	20.0	23.3	24.9
10	22.5	25.8	27.4
11	25.0	28.3	29.9
12	27.5	30.8	32.4
13	30.0	33.3	34.9
14	32.5	35.8	37.4
15	35.0	38.3	39.9
16	37.5	40.8	42.4
17	40.0	43.3	44.9
18	42.5	45.8	47.4

COLOR CODE	
BLANK	NATURAL
A	BLACK
B	BROWN
C	RED
D	ORANGE
E	YELLOW
F	GREEN
G	BLUE
H	PURPLE
J	GREY
K	WHITE
M	MILKY YELLOW
Q	BRICK RED
U	MILKY WHITE

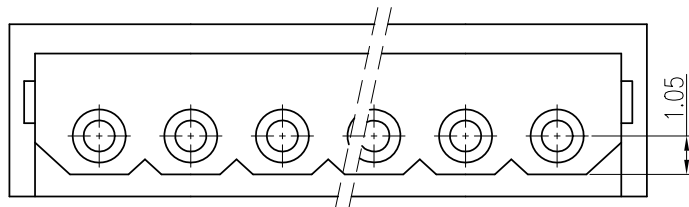
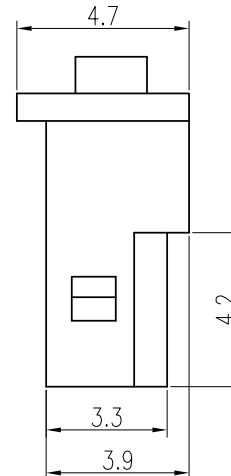
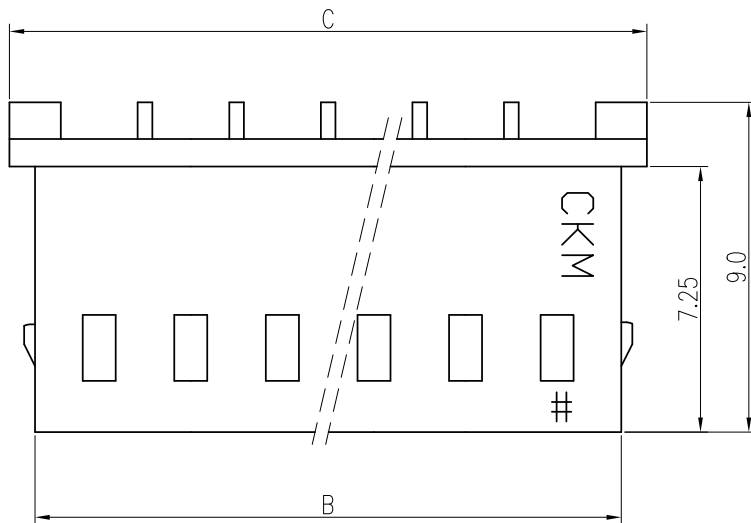

TOLERANCE		PART NO.		朝貴電子股份有限公司 CKM ELECTRONICS CO., LTD.		
X.	X.XXX ±0.10	2503H-XP-X-XX				
X.X	±0.30	DRAWING NO.		TITLE: 2.5mm PITCH CRIMP TERMINAL SOCKET		
X.XX	±0.20	C-250301XX-XX				
UNIT: mm		APPROVED BY	CHECKED BY	DRAWN BY	PAGE	REV.
DWG TYPE.		Angel.chen	Sun.lee	Angel.tong	10F2	F
Customer Drawing		2023.07.05	2023.07.05	2023.07.05	SCALE	
					5 : 1	

F	EC-23071607	ADD P/N LIST	Angel.tong	2023.07.05
E	EC-23021450	移除CSA Logo	周桂林	2023.02.17
REV.	ECN NO	REVISION RECORD	DRAW	DATE

RoHS



CUST INFORMATION.

PART NO.	DRAWING NO.	REV.
----------	-------------	------

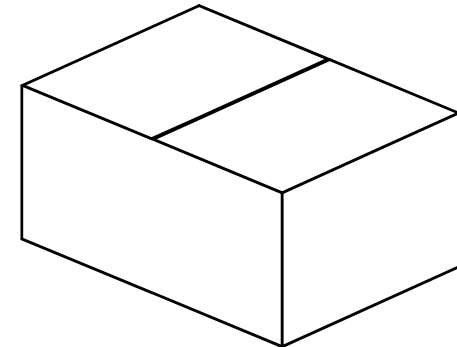
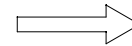
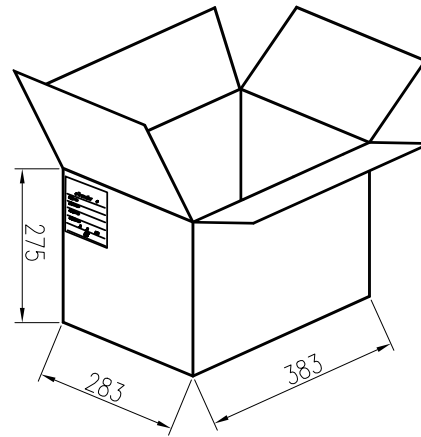
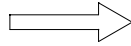
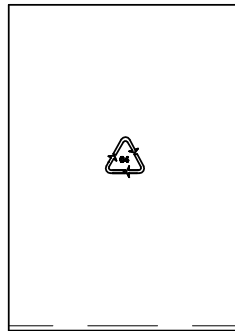
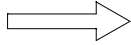
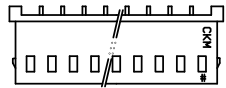

POS	PE BAG/PSC	CARTON/PCS	GROSS WEIGHT	NET WEIGHT	POS	PE BAG/PSC	CARTON/PCS	GROSS WEIGHT	NET WEIGHT
2	600PCS	14400PCS	1.77Kg	2.25Kg	11	500PCS	8000PCS	4.37Kg	4.85Kg
3	600PCS	14400PCS	2.45Kg	2.93Kg	12	300PCS	4800PCS	2.85Kg	3.33Kg
4	600PCS	14400PCS	3.12Kg	3.6Kg	13	300PCS	4800PCS	3.07Kg	3.55Kg
5	600PCS	14400PCS	3.80Kg	4.28Kg	14	300PCS	4800PCS	3.29Kg	3.77Kg
6	500PCS	8000PCS	2.48Kg	2.96Kg	15	300PCS	4800PCS	3.52Kg	4.0Kg
7	500PCS	8000PCS	2.86Kg	3.34Kg	16	300PCS	4800PCS	3.75Kg	4.23Kg
8	500PCS	8000PCS	3.24Kg	3.72Kg	17	300PCS	4800PCS	3.97Kg	4.45Kg
9	500PCS	8000PCS	3.61Kg	4.09Kg	18	300PCS	4800PCS	4.2Kg	4.68Kg
10	500PCS	8000PCS	3.99Kg	4.47Kg					

TOLERANCE X. X.XXX ±0.10 X.X ±0.30 X.XX ±0.20 Angular ±2°		PART NO. 2503H-XP-X-XX		朝貴電子股份有限公司 CKM ELECTRONICS CO., LTD.	
UNIT: mm		DRAWING NO. C-250301XX-XX		TITLE: 2.5mm PITCH CRIMP TERMINAL SOCKET	
DWG TYPE. Customer Drawing		APPROVED BY Angel.chen 2023.07.05	CHECKED BY Sun.lee 2023.07.05	DRAWN BY Angel.tong 2023.07.05	PAGE 20F2 SCALE 5:1
				REV. F	

F	EC-23071607	ADD P/N LIST	Angel.tong	2023.07.05
E	EC-23021450	移除CSA Logo	周桂林	2023.02.17
REV.	ECN NO	REVISION RECORD	DRAW	DATE