

RoHS



CUST INFORMATION.

PART NO. NA	DRAWING NO. NA	REV. NA
----------------	-------------------	------------

NOTE:

- MATERIAL SPECIFICATION:
 - INSULATOR: NYLON 66 UL 94V-0 OR V2
 - CONTACT: $\phi 0.70\text{mm}$ COPPER ALLOY
- FINISH: TIN PLATED
- BILL OF PART NO:

\triangle 2503WV-XP-XX-XX-XX-HF

MATERIAL: BLANK: NYLON 66 UL 94V-0
 V2= NYLON 66 UL 94V-2
 LOGO: BLANK=CKM LOGO
 NS=W/OUT LOGO
 COLOR: BLANK(NATURAL) OR A~U
 FINISH
 B: BRIGHT TIN PLATED

NO. OF CIRCUITS: 2~16

- FOR COLOR, AVAILABILITY, DELIVERY & MOQ, CONTACT CKM
- DIMENSIONAL & ORDERING INFORMATION

POS	A	B
2	2.50	7.5
3	5.00	10.0
4	7.50	12.5
5	10.00	15.0
6	12.50	17.5
7	15.00	20.0
8	17.50	25.5
9	20.00	25.0
10	25.50	27.5
11	25.00	30.0
12	27.50	32.5
13	30.00	35.0
14	32.50	37.5
15	35.00	40.0
16	37.50	42.5
17	40.00	45.0
18	42.50	47.5

COLOR CODE	
BLANK	NATURAL
K	WHITE
M	MILKY YELLOW

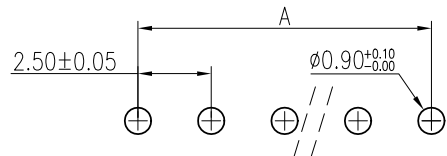
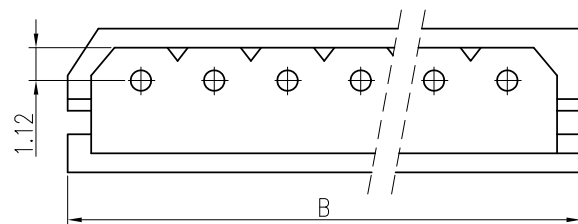

RECOMMENDED PCB LAYOUT
 PCB THK=1.6mm

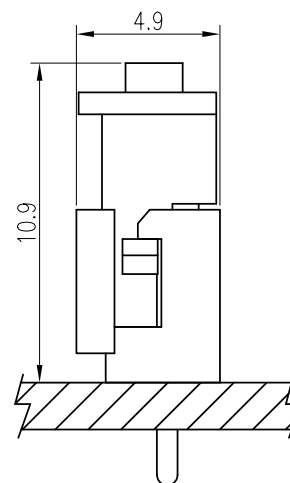
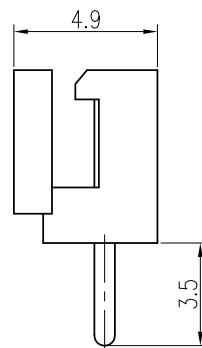
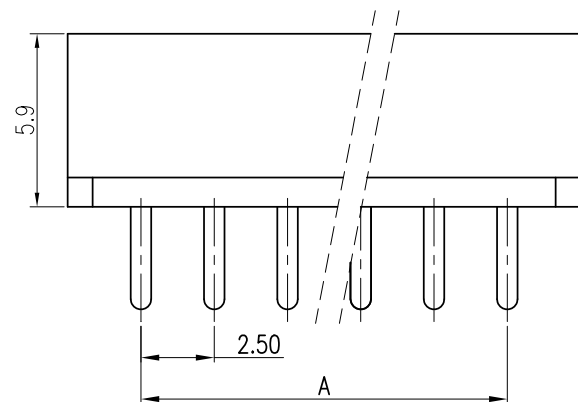

TOP ENTRY TYPE

TOLERANCE X. X.XXX ± 0.10 X.X ± 0.30 X.XX ± 0.20		PART NO. 2503WV-XP-XX-XX-XX-HF		朝貴電子股份有限公司 CKM ELECTRONICS CO., LTD.	
Angular $\pm 2^\circ$		DRAWING NO. C-25030201-XX		TITLE. CKM2503 SERIES	
UNIT: mm		APPROVED BY IVAN SU 2023.02.17	CHECKED BY 李德亮 2023.02.17	DRAWN BY 周桂林 2023.02.17	PAGE 1 OF 2 SCALE 4 : 1
DWG TYPE. Customer Drawing				REV. E	

E	EC-23021450	移除CSA Logo	周桂林	2023.02.17
D	EC-21070928	UPDATE DRAWING	Angel.tong	2021.07.05
REV.	ECN NO	REVISION RECORD	DRAW	DATE

1 RoHS



6 CUST INFORMATION.

PART NO. NA	DRAWING NO. NA	REV. NA
----------------	-------------------	------------

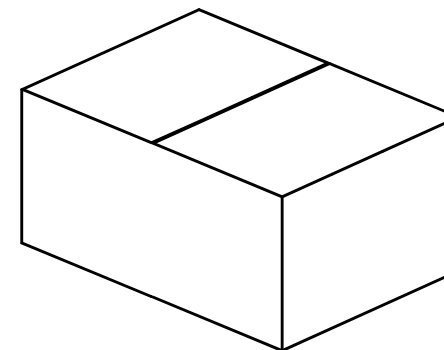
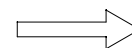
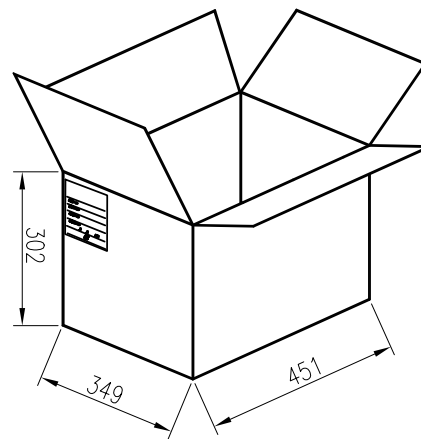
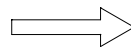
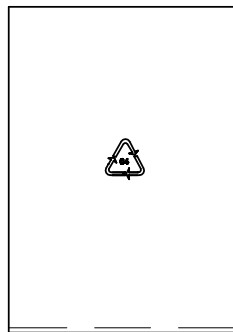
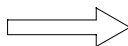
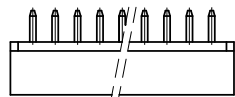

POS	PE BAG/PSC	CARTON/PCS	GROSS WEIGHT	NET WEIGHT	POS	PE BAG/PSC	CARTON/PCS	GROSS WEIGHT	NET WEIGHT
2	1000PCS	60000PCS	10.8Kg	12.3Kg	11	1000PCS	15000PCS	12.6Kg	14.1Kg
3	1000PCS	55000PCS	11.825Kg	13.325Kg	12	1000PCS	15000PCS	13.8Kg	15.3Kg
4	1000PCS	45000PCS	13.275Kg	14.775Kg	13	1000PCS	13000PCS	13.0Kg	14.5Kg
5	1000PCS	35000PCS	13.125Kg	14.625Kg	14	1000PCS	12000PCS	12.96Kg	14.46Kg
6	1000PCS	30000PCS	13.65Kg	15.15Kg	15	1000PCS	12000PCS	13.92Kg	15.42Kg
7	1000PCS	30000PCS	16.2Kg	17.7Kg	16	1000PCS	10000PCS	12.4Kg	13.9Kg
8	1000PCS	20000PCS	12.4Kg	13.9Kg	17	1000PCS	10000PCS	13.2Kg	14.7Kg
9	1000PCS	20000PCS	13.6Kg	15.1Kg	18	1000PCS	9000PCS	12.6Kg	14.1Kg
10	1000PCS	20000PCS	15.2Kg	16.7Kg					



TOLERANCE X. X.XXX ±0.10 X.X ±0.30 X.XX ±0.20 Angular ±2°		PART NO. 2503WV-XP-XX-XX-XX-HF		朝貴電子股份有限公司 CKM ELECTRONICS CO., LTD.	
UNIT: mm		DRAWING NO. C-25030201-XX		TITLE. CKM2503 SERIES	
DWG TYPE. Customer Drawing		APPROVED BY IVAN SU 2023.02.17	CHECKED BY 李德亮 2023.02.17	DRAWN BY 周桂林 2023.02.17	PAGE 2 OF 2 SCALE 4 : 1
				REV. E	

E	EC-23021450	移除CSA Logo	周桂林	2023.02.17
D	EC-21070928	UPDATE DRAWING	Angel.tong	2021.07.05
REV.	ECN NO	REVISION RECORD	DRAW	DATE