

RoHS

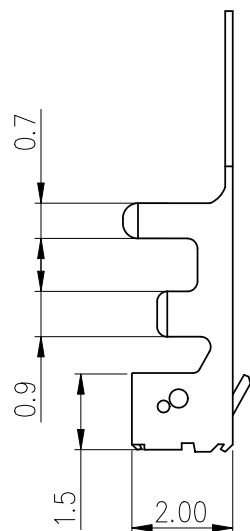
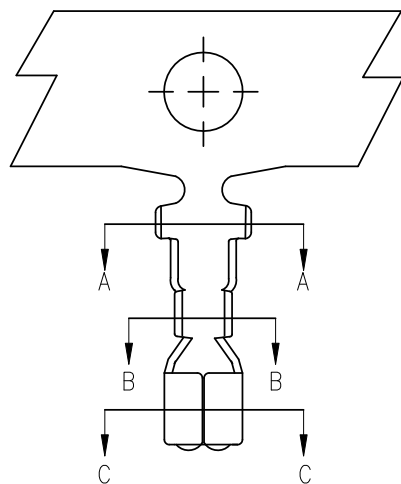

NOTE:

1. TERMINAL MATERIAL: PHOSPHOR BRONZE
2. PLATED: TIN-PLATED
3. APPLICABLE WIRES: AWG#24-#32
4. INSULATION: OD : 0.9-2.0mm
5. PACKAGE: REEL
6. BILL OF PART NO:

2006 TOP-X X

P: PHOSPHOR BRONZE

PLATING TYPE:
1=PRE-TIN PLATED
2=POST-TIN PLATED

FINISH:
A=MATTE TIN PLATED
B=BRIGHT TIN PLATED
C=GOLD PLATED

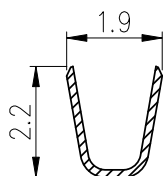

SEC A-A

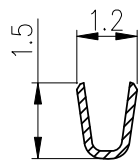

SEC B-B

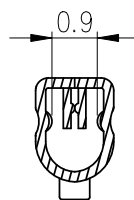

SEC C-C

CKM
2016.12.30
研發部

C		ADD PACKAGE	Li Song	2016.12.26
B		UPGRADE DRAWING		2009.03.18
REV.	ECN NO	REVISION RECORD	DRAW	DATE

TOLERANCE X. X.XXX ±0.10 X.X ±0.30 X.XX ±0.20 Angular ±2°		PART NO. 2006TOP-XX		朝貴電子股份有限公司 CKM ELECTRONICS CO., LTD.	
UNIT: mm DWG TYPE. Customer Drawing		DRAWING NO. C-200603XX		DESCRIPTION 2006 TERMINAL	
APPROVED BY Angus Chen 2016.12.26		CHECKED BY Baohua Lee 2016.12.26		DRAWN BY Li Song 2016.12.26	
				PAGE 1 OF 2 SCALE 4 : 1	
				REV. C	

RoHS

REEL

PRODUCT

LABEL

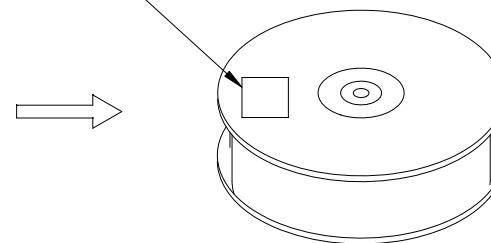
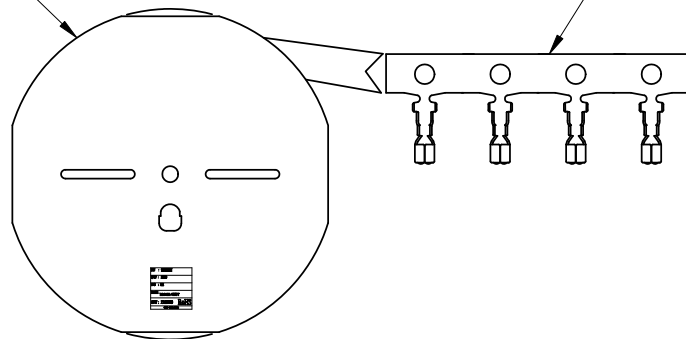
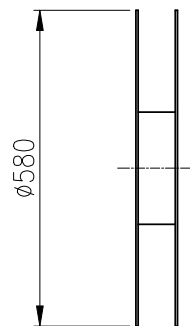

PCS/REEL	PCS/CARTON	GROSS WEIGHT(KG)	NET WEIGHT(KG)
10000	120000	15.00	11.28

CARTON

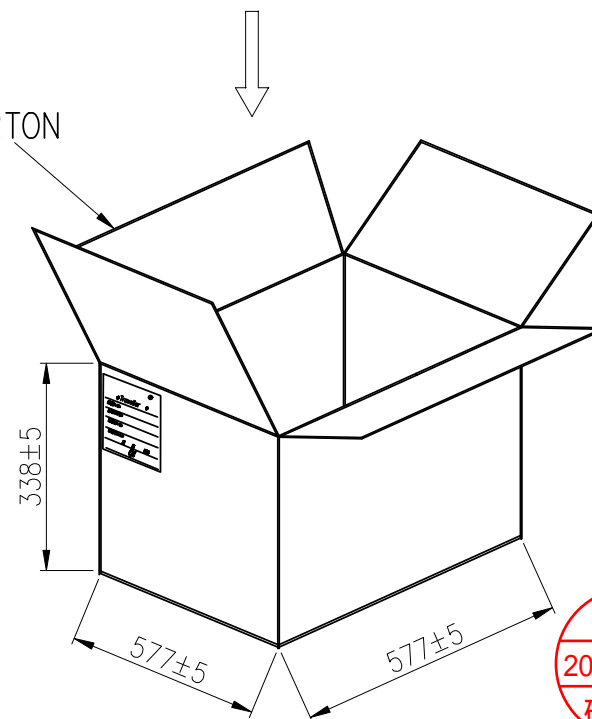
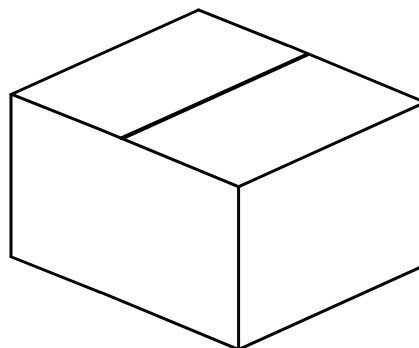

CKM
2016.12.30
研發部

TOLERANCE		PART NO.		朝貴電子股份有限公司 CKM ELECTRONICS CO., LTD.	
X.	X.XXX ±0.10	2006TOP-XX		DESCRIPTION 2006 TERMINAL	
X.X	±0.30	DRAWING NO.			
X.XX	±0.20	C-200603XX		DRAWN BY	
UNIT: mm		APPROVED BY	CHECKED BY	Li Song	PAGE
DWG TYPE.		Angus Chen	Baohua Lee	2016.12.26	2 OF 2
Customer Drawing		2016.12.26	2016.12.26	Li Song	SCALE
				2016.12.26	4 : 1
					REV.
					C

REV.	ECN NO	REVISION RECORD	DRAW	DATE
C		ADD PACKAGE	Li Song	2016.12.26
B		UPGRADE DRAWING		2009.03.18