

RoHS

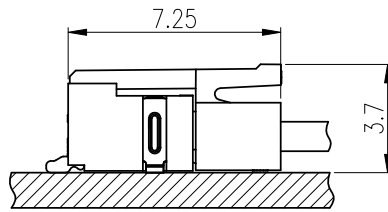
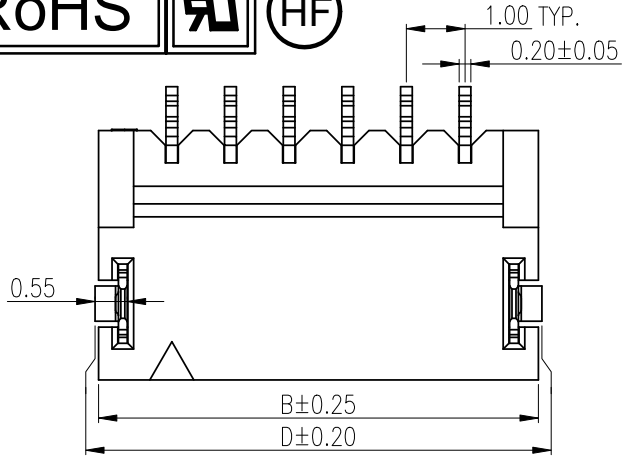

ASSEMBLY LAYOUT
SIDE ENTRY TYPE
SCALE:1/2

NOTES:

1. MATERIAL SPECIFICATION

- 1.1 INSULATION: NYLON 6T UL 94V-0(NATURAL).
- 1.2 CONTACT: THICK 0.20mm BRASS.
- 1.3 SOLDER TAB: THICK 0.15mm BRASS.

2. PLATING SPECIFICATION

- 2.1 CONTACT: TIN OR GOLD PLATING.
- 2.2 SOLDER TAB: MATTE-TIN PLATED.

3. BILL OF PART NO:

A1004WR-XX-AA-HF

NO OF CIRCUITS: 02~12

HF=HALOGEN FREE
FINISH:A=MATTE-Tin PLATING
B=GOLD FLASH PLATING
(CONTACT AREA)

4. FOR COLOR, AVAILABILITY, DELIVERY & MOQ, CONTACT CKM.

5. DIMENSIONAL

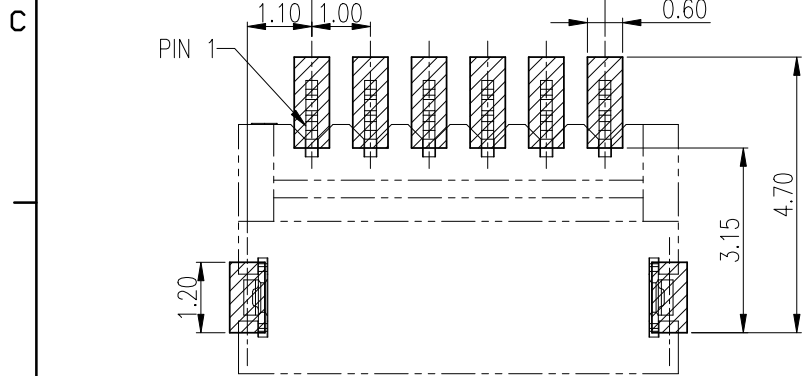
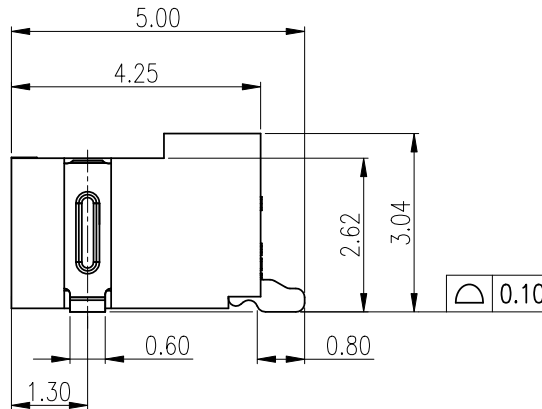
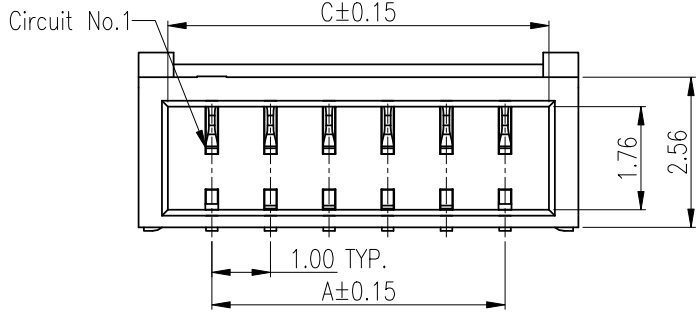

RECOMMENDED P.C.B BOARD LAYOUT
GENERAL TOLERANCE ±0.05

POS.	A	B	C	D
02	—	3.5	2.5	3.62
03	2.0	4.5	3.5	4.62
04	3.0	5.5	4.5	5.62
05	4.0	6.5	5.5	6.62
06	5.0	7.5	6.5	7.62
07	6.0	8.5	7.5	8.62
08	7.0	9.5	8.5	9.62
09	8.0	10.5	9.5	10.62
10	9.0	11.5	10.5	11.62
11	10.0	12.5	11.5	12.62
12	11.0	13.5	12.5	13.62



TOLERANCE		PART NO.		朝貴電子股份有限公司 CKM ELECTRONICS CO., LTD.	
X. X.XXX ±0.10		A1004WR-XX-AA-HF			
X.X ±0.30		DRAWING NO.		DESCRIPTION 1.0mm PITCH WAFER R/A SMT TYPE	
X.XX ±0.20	Angular ±2°	C-A1004WR-XX-AA-HF			
UNIT: mm		APPROVED BY	CHECKED BY	DRAWN BY	PAGE
DWG TYPE.		Angus.Chen	Angus.Chen	Rock	1 OF 2
Customer Drawing		2019.09.16	2019.09.16	2019.09.16	SCALE
					10 : 1
					REV.
					G

G	EC-19090391	UPGRADE DRAWING	Rock	2019.09.16
F		EC SOLDER TAB & FINISH	Rock	2017.12.14
REV.	ECN NO	REVISION RECORD	DRAW	DATE

RoHS

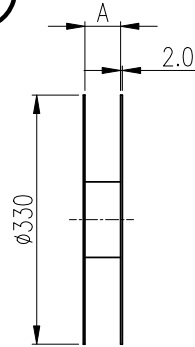

PEELING STRENGTH:10~130GF
PEELING SPEED:300mm/Min

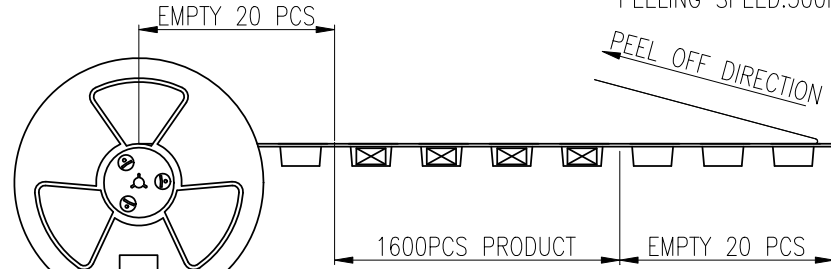

LABLE
STICK TO
THE BACK

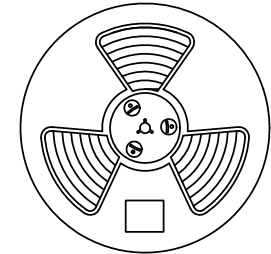
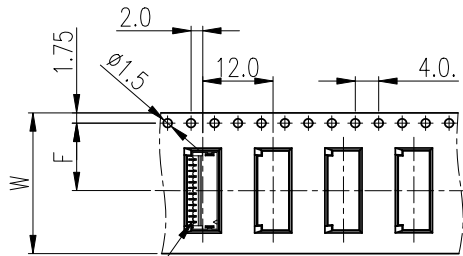

TABLE 1:

POS.	A	W	F	H
2~5	16.5	16.0	7.5	265
6~12	24.5	24.0	11.5	285



PRODUCT

TABLE 2:

POS	PCS/REEL	PCS/CARTON	NET WEIGHT (KG)	CROSS WEIGHT (KG)
2	1600	17600	0.85	4.67
3	1600	17600	1.07	4.89
4	1600	17600	1.28	5.10
5	1600	17600	1.50	5.32
6	1600	14400	1.40	5.33
7	1600	14400	1.58	5.51
8	1600	14400	1.75	5.68
9	1600	14400	1.93	5.86
10	1600	14400	2.10	6.03
11	1600	14400	2.28	6.21
12	1600	14400	2.45	6.38

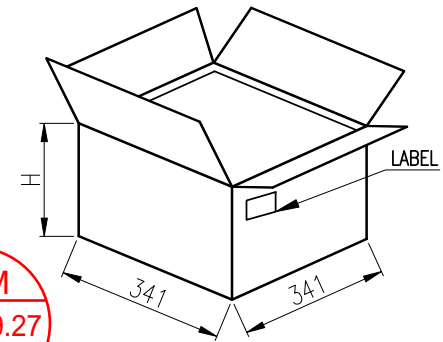
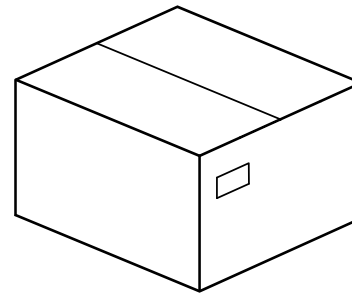

TOLERANCE X. X.XXX ±0.10 X.X ±0.30 X.XX ±0.20 Angular ±2°		PART NO. A1004WR-XX-AA-HF		朝貴電子股份有限公司 CKM ELECTRONICS CO., LTD.	
UNIT: mm		DRAWING NO. C-A1004WR-XX-AA-HF		DESCRIPTION 1.0mm PITCH WAFER R/A SMT TYPE PACKING	
DWG TYPE. Customer Drawing		APPROVED BY Angus.Chen 2019.09.16	CHECKED BY Angus.Chen 2019.09.16	DRAWN BY Rock 2019.09.16	PAGE 2 OF 2 SCALE 10 : 1
					REV. G

G	EC-19090391	UPGRADE DRAWING	Rock	2019.09.16
F		EC SOLDER TAB & FINISH	Rock	2017.12.14
REV.	ECN NO	REVISION RECORD	DRAW	DATE