

RoHS



CUST INFORMATION.

PART NO.	DRAWING NO.	REV.
----------	-------------	------

NOTE:

1. MATERIAL: NYLON 66 UL 94V-0
2. RoHS & HALOGEN-FREE COMPLIANCE
3. BILL OF PART NO.

2001H-XP-X-HC-HF

CIRCUITS: 2~16

COLOR: BLANK=NATURAL

- A=BLACK B=BROWN
- C=RED D=ORANGE
- E=YELLOW F=GREEN
- G=BLUE H=PURPLE
- J=GREY K=WHITE
- M=MILKY YELLOW
- Q=BRICK RED U=MILKY WHITE



4. FOR AVAILABILITY, DELIVERY & MOQ, CONTACT CKM
5. DIMENSIONAL

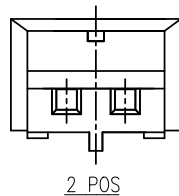
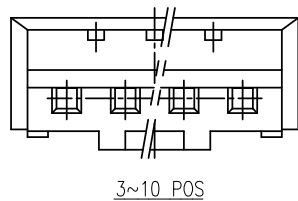
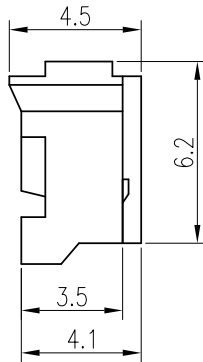
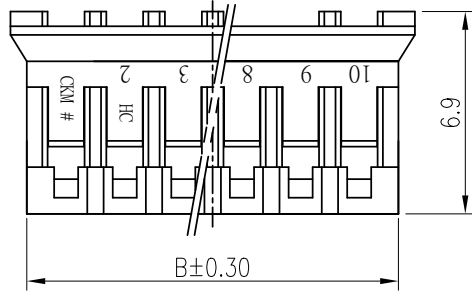
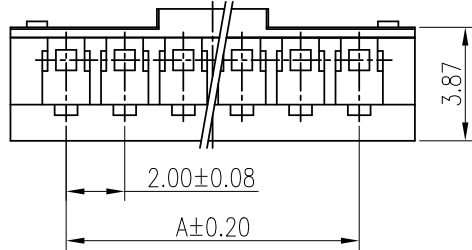

POS	A	B
2	2.00	4.7
3	4.00	6.7
4	6.00	8.7
5	8.00	10.7
6	10.00	12.7
7	12.00	14.8
8	14.00	16.8

POS	A	B
9	16.00	18.8
10	18.00	20.8
11	20.00	22.8
12	22.00	24.8
13	24.00	26.8
14	26.00	28.8
15	28.00	30.8
16	30.00	32.8

<b>TOLERANCE</b>		<b>PART NO.</b>		朝貴電子股份有限公司 CKM ELECTRONICS CO., LTD.	
X. ±0.50	X.XXX ±0.15	2001H-XP-X-HC-HF			
X.X ±0.35		<b>DRAWING NO.</b>		TITLE: 2001Housing	
X.XX ±0.25	Angular ±5°	C- 2001H-XP-X-HC-HF			
		<b>UNIT:</b>		<b>APPROVED BY</b>	
		mm		Ivan_Su	
<b>DWG TYPE.</b>		<b>CHECKED BY</b>		<b>DRAWN BY</b>	
Customer Drawing		Deliang Li		Heimer	
		2021/9/28		2021/9/28	
				PAGE 10F2	
				SCALE 1:1	
				REV. B	

B	EC-21090987	ADD COLOR&11~16POS	Heimer	2021/9/28
A		NEW RELEASE	Jimmy Wang	2019.08.21
REV.	ECN NO	REVISION RECORD	DRAW	DATE

1 RoHS



6 CUST INFORMATION.

PART NO.	DRAWING NO.	REV.
----------	-------------	------

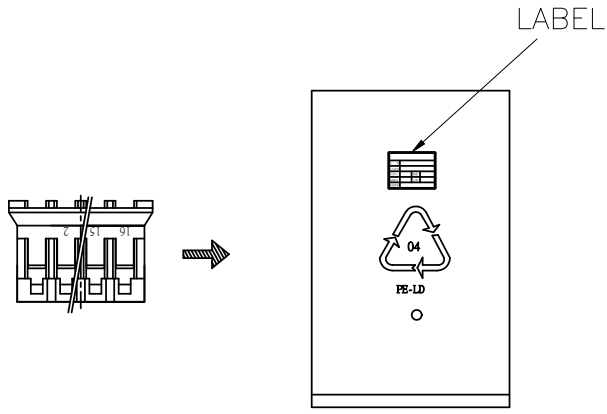

BAG

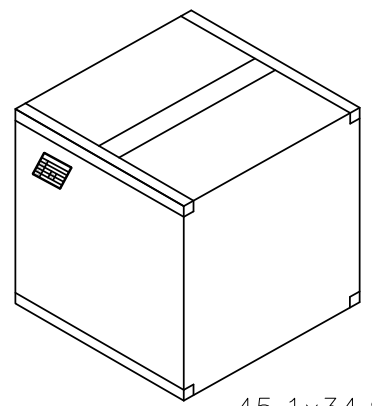

45.1x34.9x30.2cm

CARTON

POS	BAG	CARTON	Net Weight (kg)	Cross Weight (kg)
	PCS/BAG	PCS/CARTON		
2	1000	180K	12.43	13.29
3	1000	130K	12.65	13.51
4	1000	100K	10.53	11.39
5	1000	80K	11.78	12.64
6	1000	70K	12.3	13.16
7	1000	60K	11.84	12.7
8	1000	50K	11.11	11.97
9	1000	45K	11.14	12.0
10	1000	40K	10.86	11.72
11	1000	35K	10.65	11.51
12	1000	30K	9.74	10.6
13	1000	30K	10.69	11.55
14	1000	30K	11.39	12.25
15	1000	25K	9.97	10.83
16	1000	25K	10.6	11.46

- △ B
- △ B
- △ B
- △ B
- △ B
- △ B

<b>TOLERANCE</b>		PART NO. 2001H-XP-X-HC-HF		朝貴電子股份有限公司 CKM ELECTRONICS CO., LTD.	
X. ±0.50	X.XXX ±0.15	DRAWING NO. C- 2001H-XP-X-HC-HF			
X.X ±0.35		APPROVED BY Ivan_Su		CHECKED BY Deliang Li	DRAWN BY Heimer
X.XX ±0.25	Angular ±5°	2021/9/28		2021/9/28	2021/9/28
UNIT: mm DWG TYPE: Customer Drawing		PAGE 2OF2		REV. B	
		SCALE 1 : 1			

B	EC-21090987	ADD COLOR&11~16POS	Heimer	2021/9/28
A		NEW RELEASE	Jimmy Wang	2019.08.21
REV.	ECN NO	REVISION RECORD	DRAW	DATE