

RoHS

A

B

C

D

A

B

C

D

NOTES:

1. MATERIAL SPECIFICATION:
 - 1.1 INSULATION:PA9T UL 94V-0.
 - 1.2 CONTACT:THICK 0.20mm BRASS.
 - 1.3 SOLDER TAB:THICK 0.20mm BRASS.

2. FINISH:
 - 2.1 CONTACT:MATTE TIN/GOLD PLATED.
 - 2.2 SOLDER TAB:MATTE TIN PLATED.

3. BILL OF PART NO:

1001WVS-XP-XX

COLOR: BLANK(NATURAL)
A=BLACK

FINISH: A=MATTE TIN PLATED
C=GOLD FLASH PLATED

NO.OF CIRCUITS:2~20

4. FOR COLOR,AVAILABILITY,DELIVERY & MOQ,CONTACT CKM.

5. DIMENSIONAL

POS	A	B	C	D
2	1.00	2.50	4.00	3.30
3	2.00	3.50	5.00	4.30
4	3.00	4.50	6.00	5.30
5	4.00	5.50	7.00	6.30
6	5.00	6.50	8.00	7.30
7	6.00	7.50	9.00	8.30
8	7.00	8.50	10.00	9.30
9	8.00	9.50	11.00	10.30
10	9.00	10.50	12.00	11.30
11	10.00	11.50	13.00	12.30
12	11.00	12.50	14.00	13.30
13	12.00	13.50	15.00	14.30
14	13.00	14.50	16.00	15.30
15	14.00	15.50	17.00	16.30
16	15.00	16.50	18.00	17.60
17	16.00	17.50	19.00	18.30
18	17.00	18.50	20.00	19.30
19	18.00	19.50	21.00	20.30
20	19.00	20.50	22.00	21.30

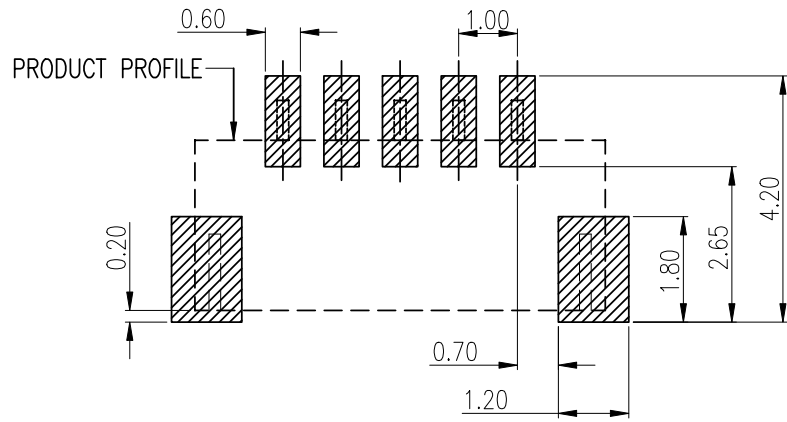

RECOMMENDED PCB LAYOUT
GENERAL TOLERANCE ±0.05

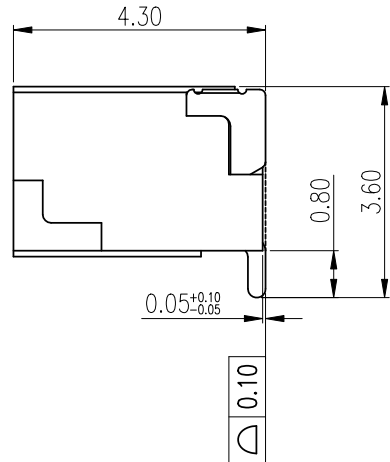
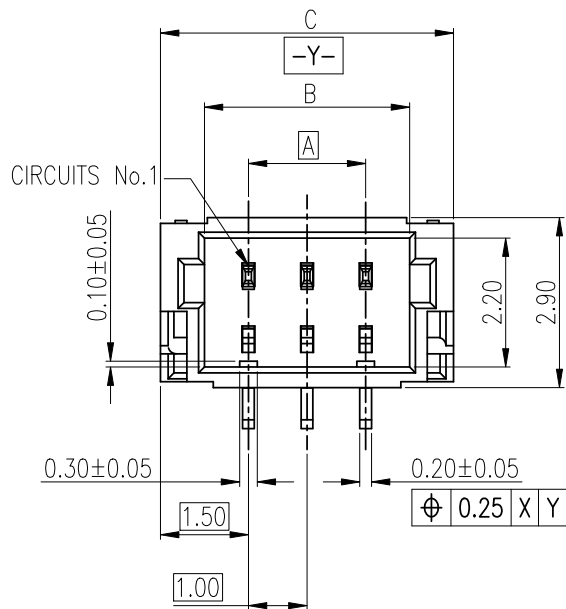

TOLERANCE X. X.XXX ±0.10 X.X ±0.30 X.XX ±0.20 Angular ±2°		PART NO. 1001WVS-XP-XX		朝貴電子股份有限公司 CKM ELECTRONICS CO., LTD.	
		DRAWING NO. C-10010208-XX		DESCRIPTION 1.0mm PITCH VERTICAL SMT TYPE CONNECTOR	
DWG TYPE. Customer Drawing		APPROVED BY Angus.Chen 2021.04.24	CHECKED BY Sun.Lee 2021.04.24	DRAWN BY Rock 2021.04.24	PAGE 1 OF 3 SCALE 8 : 1
					REV. G

G	EC-21040884	UPGRADE DRAWING	Rock	2021.04.24
F		UPGRADE DRAWING	Rock	2017.05.04
REV.	ECN NO	REVISION RECORD	DRAW	DATE

RoHS

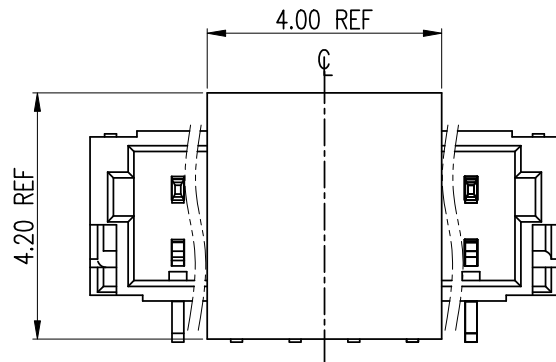

POS 2,4,6,8,10,12,14,16,18,20

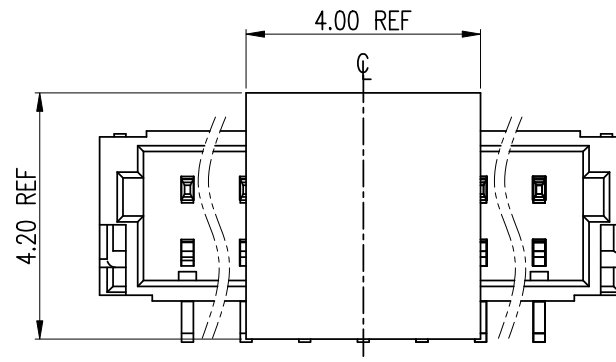

POS 3,5,7,9,11,13,15,17,19

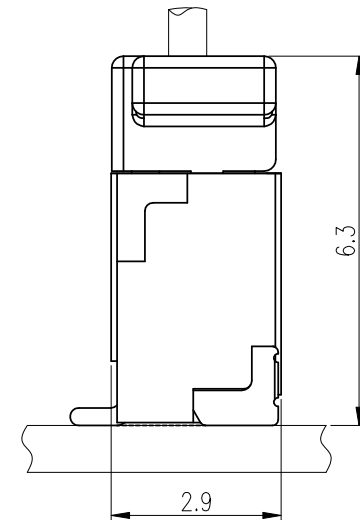

ASSEMBLY LAYOUT
TOP ENTRY TYPE

G	EC-21040884	UPGRADE DRAWING	Rock	2021.04.24
F		UPGRADE DRAWING	Rock	2017.05.04
REV.	ECN NO	REVISION RECORD	DRAW	DATE

TOLERANCE X. X.XXX ±0.10 X.X ±0.30 X.XX ±0.20 Angular ±2°		PART NO. 1001WVS-XP-XX		朝貴電子股份有限公司 CKM ELECTRONICS CO., LTD.	
		DRAWING NO. C-10010208-XX		DESCRIPTION 1.0mm PITCH VERTICAL SMT TYPE CONNECTOR	
DWG TYPE. Customer Drawing		APPROVED BY Angus.Chen 2021.04.24	CHECKED BY Sun.Lee 2021.04.24	DRAWN BY Rock 2021.04.24	PAGE 2 OF 3 SCALE 8 : 1
					REV. G

RoHS

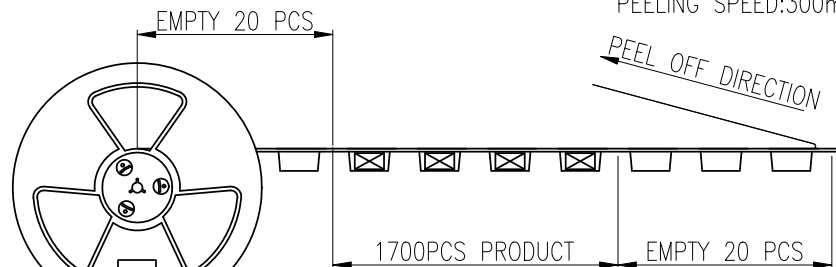
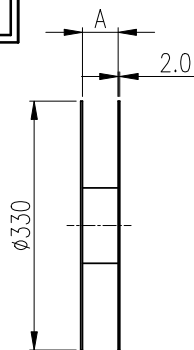

CKM
2021.04.24
研发部

LABLE
STICK TO
THE BACK

TABLE 2:

POS	PCS/REEL	PCS/CARTON	NET WEIGHT (kg)	CROSS WEIGHT (kg)
2	1700	20400	1.56	8.23
3	1700	15300	1.36	6.52
4	1700	15300	1.54	6.71
5	1700	15300	1.72	6.89
6	1700	10200	1.27	4.94
7	1700	10200	1.39	5.06
8	1700	10200	1.52	5.18
9	1700	10200	1.64	5.30
10	1700	10200	1.76	5.43
11	1700	10200	1.88	5.55
12	1700	10200	2.01	5.67
13	1700	10200	2.13	5.79
14	1700	8500	1.88	5.04
15	1700	8500	1.98	5.14
16	1700	8500	2.08	5.25
17	1700	8500	2.18	5.35
18	1700	6800	1.83	4.49
19	1700	6800	1.91	4.58
20	1700	6800	1.99	4.66

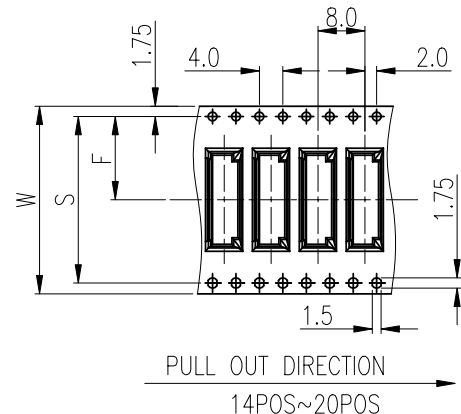
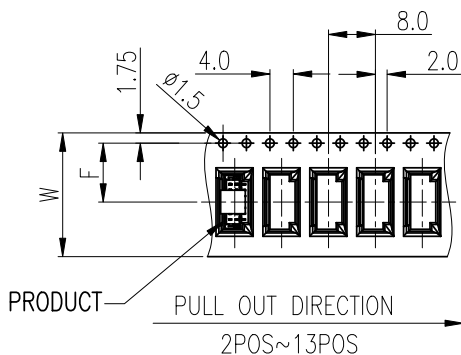
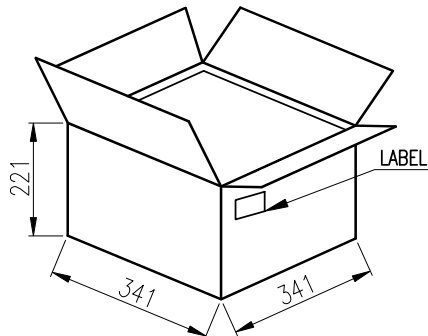
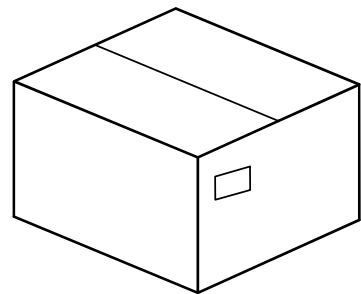

TABLE 1:

POS.	A	W	S	F
2	12.5	12.0		5.5
3~5	16.5	16.0		7.5
6~13	24.5	24.0		11.5
14~17	32.5	32.0	28.4	14.2
18~20	44.5	44.0	40.4	20.2



TOLERANCE X. X.XXX ±0.10 X.X ±0.30 X.XX ±0.20 Angular ±2°		PART NO. 1001WVS-XP-XX		朝貴電子股份有限公司 CKM ELECTRONICS CO., LTD.	
		DRAWING NO. C-10010208-XX		DESCRIPTION 1.0mm PITCH VERTICAL SMT TYPE CONNECTOR PACKING	
DWG TYPE. Customer Drawing		APPROVED BY Angus.Chen 2021.04.24	CHECKED BY Sun.Lee 2021.04.24	DRAWN BY Rock 2021.04.24	PAGE 3 OF 3 SCALE 8 : 1
				REV. G	

G	EC-21040884	UPGRADE DRAWING	Rock	2021.04.24
F		UPGRADE DRAWING	Rock	2017.05.04
REV.	ECN NO	REVISION RECORD	DRAW	DATE