

RoHS

HF

CKM
2023.12.25
研发部

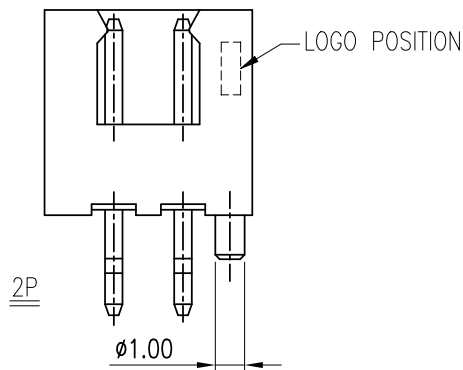
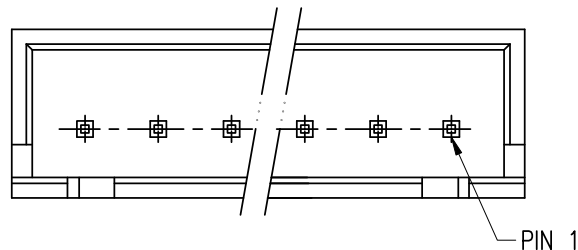

- 1. MATERIAL SPECIFICATION:
 - 1.1 INSULATOR: NYLON 66 UL 94V-0
 - 1.2 CONTACT: SQ.0.64mm COPPER ALLOY

2. FINISH: TIN PLATED

3. BILL OF PART NO:

2501WBS-XP-XX-XXX-HF

NO. OF CIRCUITS: 2~16

FINISH

B=BRIGHT TIN PLATED

PACKAGE
BLANK=PE BAG PACKAGE
VOID CIRCUITS:BLANK(STANDARD)
F: VOID CIRCUIT 3
COLOR: BLANK(NATURAL) OR A~G

4. FOR COLOR, FINISH, REFER TO THE SHEET

5. DIMENSIONAL

POS	A	B
2	2.50	7.5
3	5.00	10.0
4	7.50	12.5
5	10.00	15.0
6	12.50	17.5
7	15.00	20.0
8	17.50	22.5
9	20.00	25.0
10	25.50	27.5
11	25.00	30.0
12	27.50	32.5
13	30.00	35.0
14	32.50	37.5
15	35.00	40.0
16	37.50	42.5

COLOR CODE	
A	BLACK
C	RED
F	GREEN
G	BLUE

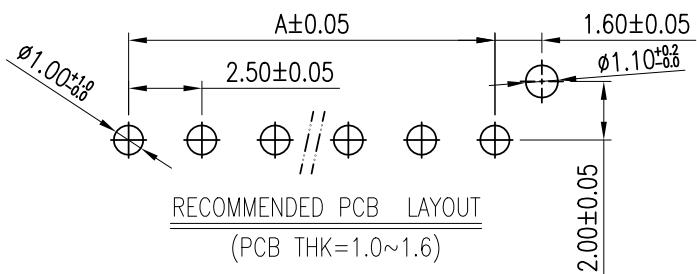
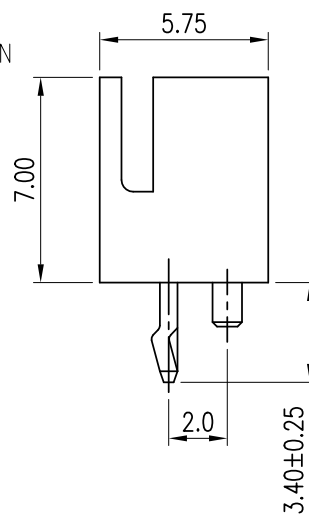
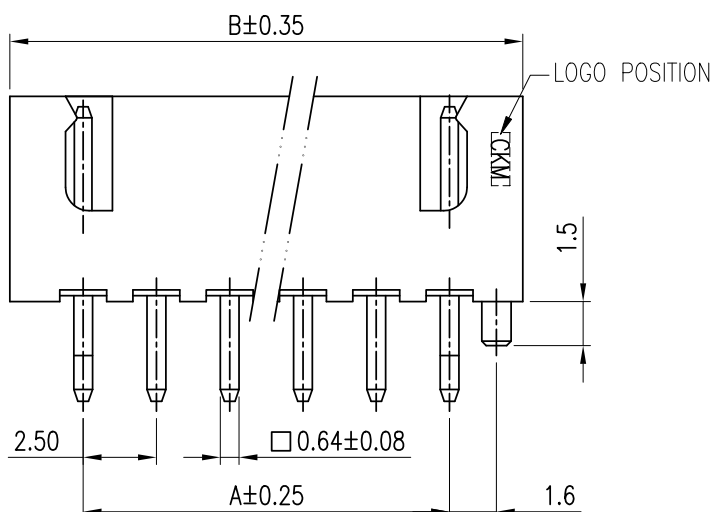

RECOMMENDED PCB LAYOUT
(PCB THK=1.0~1.6)

TOLERANCE		PART NO.		朝貴電子股份有限公司 CKM ELECTRONICS CO., LTD.	
X.	X.XXX ±0.10	2501WBS-XP-XX-XXX-HF		DESCRIPTION 2.5mm PITCH VERTICAL DIP TYPE CONNECTOR	
X.X ±0.30		DRAWING NO. C-2501WBS-XP-XX-XXX-HF			
X.XX ±0.20	Angular ±2°	APPROVED BY Angus.chen 2023.12.25		CHECKED BY Sun.lee 2023.12.25	DRAWN BY Angel.tong 2023.12.25
UNIT: mm		PAGE 1 OF 2		REV. A	
DWG TYPE. Customer Drawing		SCALE 4 : 1			

REV.	ECN NO	REVISION RECORD	DRAW	DATE
A		NEW DRAWING	Angel.tong	2023.12.25

RoHS

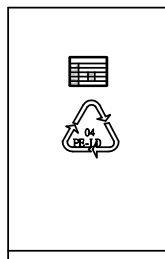
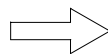

BAG

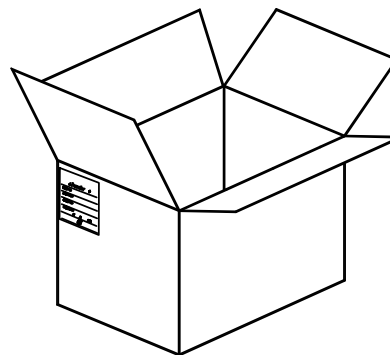
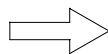

CARTON

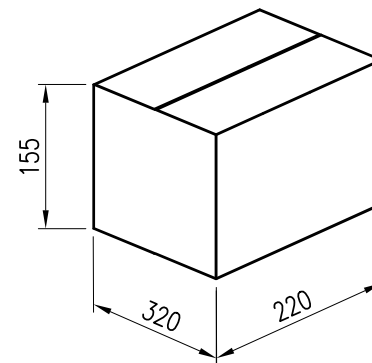
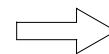

POS	PCS/BAG	PCS/CARTON
2	1000	15000
3		14000
4		12000
5		10000
6		8000
7		7000
8	5000	
9	500	5000
10		4000
11		4000
12		3500
13	250	3250
14		3000
15		3000
16		2500

TOLERANCE		PART NO.		朝貴電子股份有限公司	
X.	X.XXX ±0.10	2501WVBS-XP-XX-XXX-HF		CKM ELECTRONICS CO., LTD.	
X.X	±0.30	DRAWING NO.		DESCRIPTION	
X.XX	±0.20	C-2501WVBS-XP-XX-XXX-HF		2.5mm PITCH VERTICAL DIP TYPE CONNECTOR	
		UNIT:		APPROVED BY	
		mm		Angus.chen	
DWG TYPE.		CHECKED BY		DRAWN BY	
Customer Drawing		Sun.lee		Angel.tong	
		2023.12.25		2023.12.25	
				PAGE	
				2 OF 2	
				SCALE	
				4 : 1	
				REV.	
				A	

A		NEW DRAWING	Angel.tong	2023.12.25
REV.	ECN NO	REVISION RECORD	DRAW	DATE