

RoHS

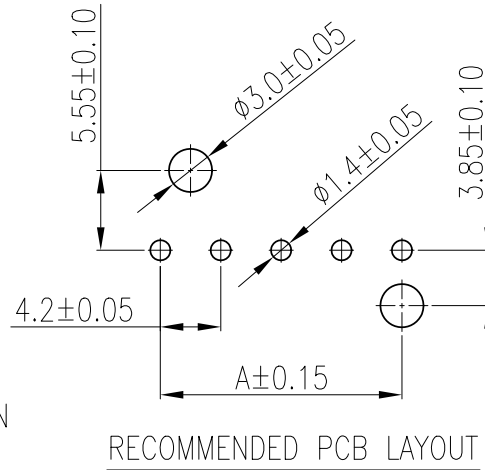

CUST INFORMATION.

PART NO.	DRAWING NO.	REV.
----------	-------------	------

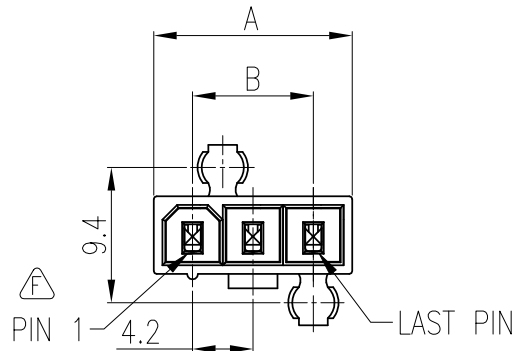

NOTES:

- MATERIAL: NYLON 66
- CONTACT MATERIAL: COPPER ALLOY.
- BILL OF PART No.
 - CKM4203-WVU-XX-X-X-XX-X-XX
 - POS: 03~05
 - INSULATOR MATERIAL:
 - 1=NYLON 66, UL 94V-0
 - 8=NYLON 66, UL 94V-2
 - FINISH
 - 0=GOLD FLASH
 - 1=50u" TIN PLATED
 - 2=100u" TIN PLATED
 - 3=15u" GOLD
 - 4=30u" GOLD
 - OPTIONAL DRAIN HOLDS:
 - 01=WITH DRAIN HOLD
 - 02=WITH/OUT DRAIN HOLD
 - CONTACT MATERIAL:
 - B=BRASS
 - BLANK=HIGH-CONDUCTIVITY COPPER ALLOY
 - BLANK=CARTON W/CKM LOGO(STANDARD)
 - NS=ALL W/O CKM LOGO

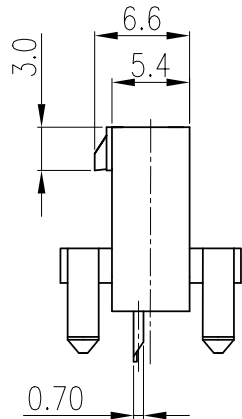
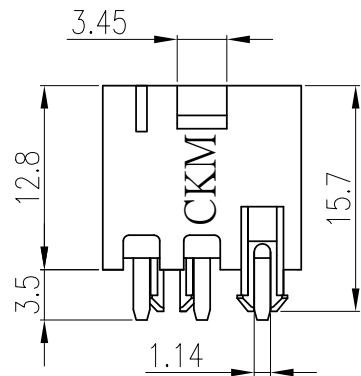

4. DIMENSIONAL

POS	A	B
03	13.8	8.4
04	18.0	12.6
05	22.2	16.8

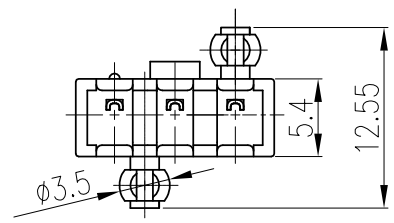
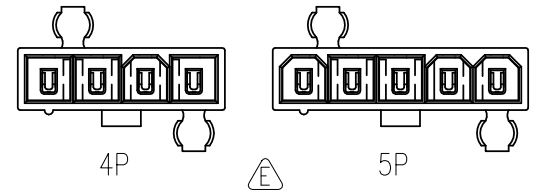

TOLERANCE X. X.XXX ±0.10 X.X ±0.30 X.XX ±0.20 Angular ±2°		PART NO. CKM4203-WVU-XX-X-X-XX-X		朝貴電子股份有限公司 CKM ELECTRONICS CO., LTD.	
UNIT: mm DWG TYPE: Customer Drawing		DRAWING NO. C-CKM4203-WVU-XX-X-X-XX-X		TITLE. 4.2mm PITCH SINGLE ROW VERTICAL TYPE	
APPROVED BY Angus.Chen 2023.10.26	CHECKED BY Sun.Lee 2023.10.26	DRAWN BY GuoXiang.Jiang 2023.10.26	PAGE 1 OF 2 SCALE 2 : 1	REV. G	

G	EC-23100174	ADD PART NUMBER W/O LOGO	GuoXiang.Jiang	2023/10/26
F	EC-20090687	UPDATE DRAWING	GuoXiang.Jiang	2020/09/05
REV.	ECN NO	REVISION RECORD	DRAW	DATE

1 RoHS



6 CUST INFORMATION.

PART NO.	DRAWING NO.	REV.
----------	-------------	------

CKM
2023.10.31
研发部

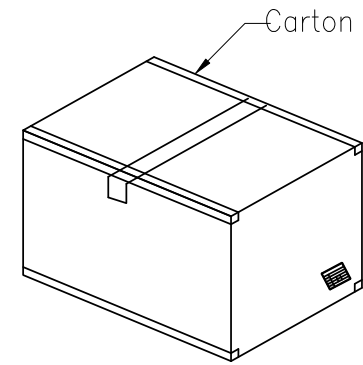
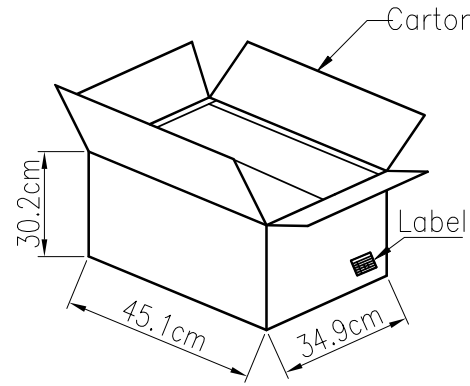
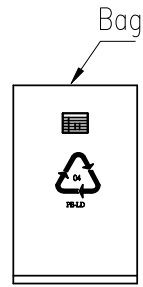
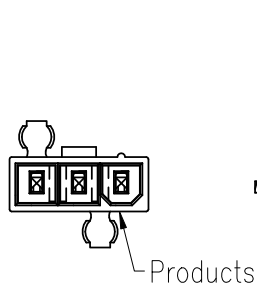

POS	Bag		Weight	
	Pcs/Bag	Pcs/Carton	N/W(kg)	G/W(kg)
03	1000	15000	11.70	13.90
04	1000	12000	12.10	14.30
05	1000	10000	12.30	14.50

TOLERANCE		PART NO.		朝貴電子股份有限公司 CKM ELECTRONICS CO., LTD.	
X.	X.XXX ±0.10	CKM4203-WVU-XX-X-X-XX-X-XX			
X.X	±0.30	DRAWING NO.		TITLE.	
X.XX	±0.20	C-CKM4203-WVU-XX-X-X-XX-X-XX		4.2mm PITCH SINGLE ROW VERTICAL TYPE	
UNIT: mm DWG TYPE. Customer Drawing		APPROVED BY	CHECKED BY	DRAWN BY	PAGE
		Angus.Chen 2023.10.26	Sun.Lee 2023.10.26	GuoXiang.Jiang 2023.10.26	2 OF 2
				SCALE	REV.
				2 : 1	G

G	EC-23100174	ADD PART NUMBER W/O LOGO	GuoXiang.Jiang	2023/10/26
F	EC-20090687	UPDATE DRAWING	GuoXiang.Jiang	2020/09/05
REV.	ECN NO	REVISION RECORD	DRAW	DATE