

RoHS

CUST INFORMATION.

PART NO.	DRAWING NO.	REV.
----------	-------------	------

CKM  
2023.10.31  
研发部

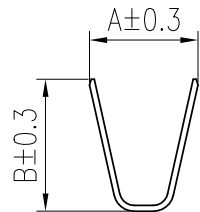
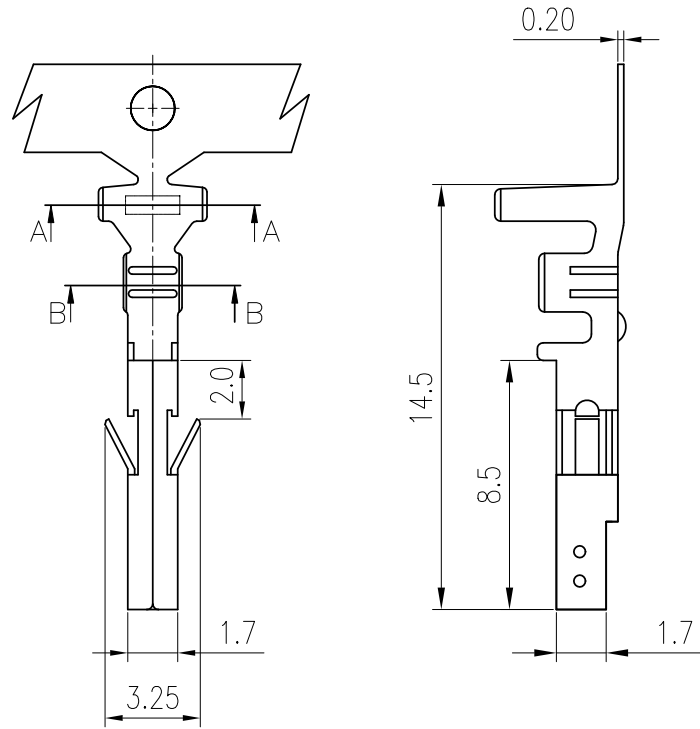

SEC A-A

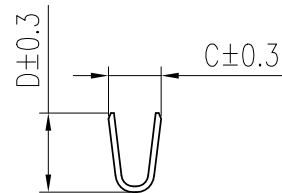

SEC B-B

NOTE:

1. MATERIAL: 0.20mm THICKNESS COPPER ALLOY
2. RoHS COMPLIANCE
3. BILL OF PART NO.

CKM4203-TBX-X-X-XX

STRUCTURE STATUS:  
LL=ULTRA-HIGH TAIL  
L=HIGH TAIL  
S=LOW TAIL



BLANK=CARTON W/CKM LOGO(STANDARD)  
NS=ALL W/O CKM LOGO

FINISH:

- 1=GOLD FLASH PLATING
- 2=TIN PLATING

MATERIAL:

- BLANK=HIGT CONDUCTIVITY COPPER ALLOY
- 1=PHOSPHOR BRONZE
- 2=BRASS

4. APPLICABLE WIRES: AWG#16~ AWG#28  
INSULATION O.D.: 1.3~2.1mm
5. DIMENSIONAL & ORDER INFORMATION:

PART NO.	A	B	C	D	APPLICABLE WIRES
CKM4203-TBS-X-X-XX	3.2	3.4	1.8	2.2	#24~#28
CKM4203-TBL-X-X-XX	3.7	4.5	1.8	2.7	#18~#22
CKM4203-TBLL-X-X-XX	3.6	4.5	3.0	2.82	#16

6. Q'TY / REEL: 5000 PCS

<b>TOLERANCE</b>		PART NO. CKM4203-TBX-X-X-XX		朝貴電子股份有限公司 CKM ELECTRONICS CO., LTD.	
X. X.X ±0.30 X.XX ±0.20	X.XXX ±0.10 Angular ±2°	DRAWING NO. C-CKM4203-TBX-X-X-XX		TITLE. 4.2mm PITCH CRIMP TERMINAL	
UNIT: mm		APPROVED BY Angus.Chen 2023.10.26	CHECKED BY Sun.Lee 2023.10.26	DRAWN BY GuoXiang.Jiang 2023.10.26	PAGE 1 OF 2 SCALE 5 : 1
DWG TYPE. Customer Drawing				REV. C	

C	EC-23100174	ADD PART NUMBER W/O LOGO	GuoXiang.Jiang	2023.10.26
B		ADD TBLL SPEC	GuoXiang.Jiang	2018.07.18
REV.	ECN NO	REVISION RECORD	DRAW	DATE

RoHS

CUST INFORMATION.

PART NO.	DRAWING NO.	REV.
----------	-------------	------

Clockwise Feed



Stick by the label

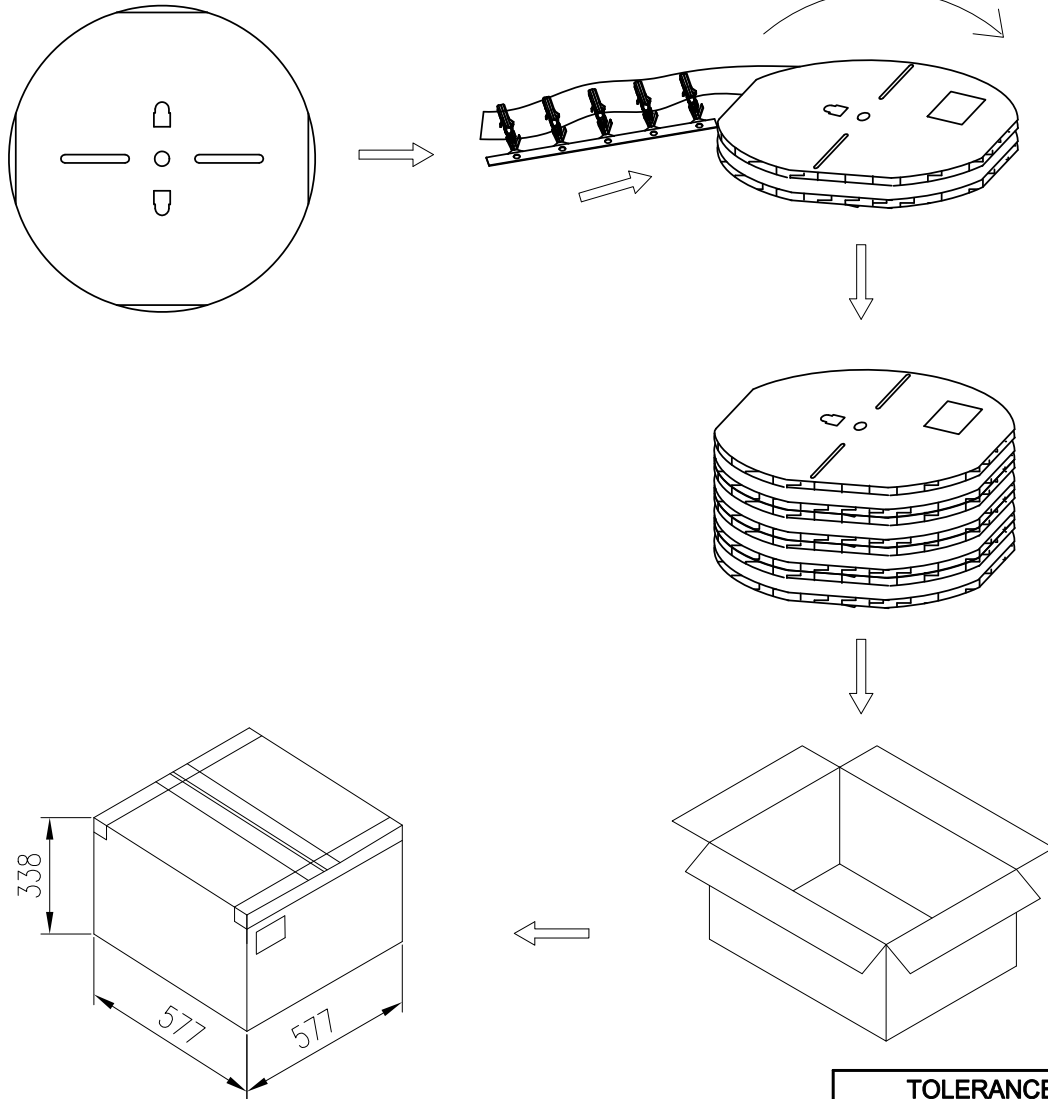

TYPE	REEL	Carton	Weight	
	Pcs/Reel	Pcs/Carton	N/W(kg)	G/W(kg)
TBS	5000	45000	18.0	19.08
TBL	4000	36000	14.4	15.48
TBLL	3000	27000	10.8	11.88

<b>TOLERANCE</b>		PART NO.	朝貴電子股份有限公司 CKM ELECTRONICS CO., LTD.		
X.	X.XXX ±0.10	CKM4203-TBX-X-X-XX	TITLE.		
X.X	±0.30	DRAWING NO.	4.2mm PITCH CRIMP TERMINAL		
X.XX	±0.20	C-CKM4203-TBX-X-X-XX	APPROVED BY	CHECKED BY	DRAWN BY
		UNIT: mm		Angus.Chen	Sun.Lee
DWG TYPE.		Customer Drawing	2023.10.26	2023.10.26	GuoXiang.Jiang
					PAGE 2 OF 2
					SCALE 5 : 1
					REV. C

C	EC-23100174	ADD PART NUMBER W/O LOGO	GuoXiang.Jiang	2023.10.26
B		ADD TBLL SPEC	GuoXiang.Jiang	2018.07.18
REV.	ECN NO	REVISION RECORD	DRAW	DATE