

RoHS

CUST INFORMATION.

| | | |
|----------|-------------|------|
| PART NO. | DRAWING NO. | REV. |
|----------|-------------|------|

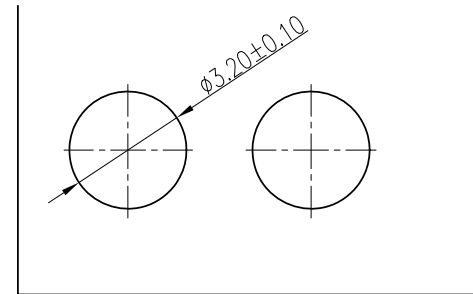
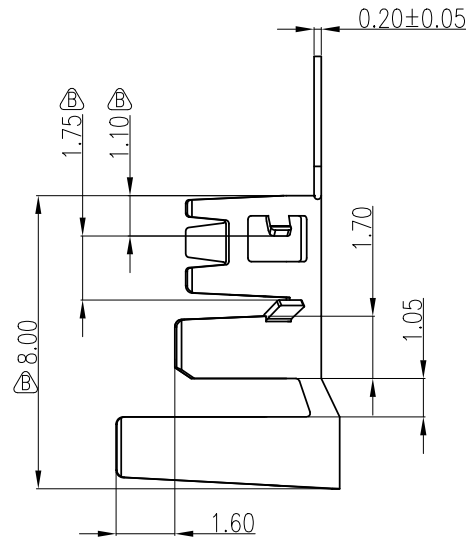
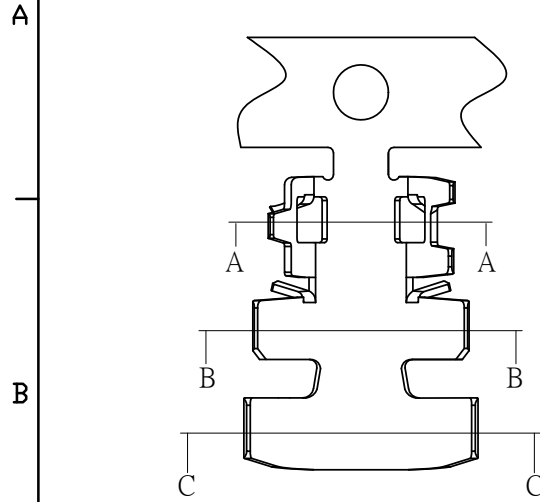

RECOMMENDED PCB LAYOUT (TOP VIEW)
 (ALL TOLERANCES ARE ±0.05)
 PCB BOARD THK 1.60mm

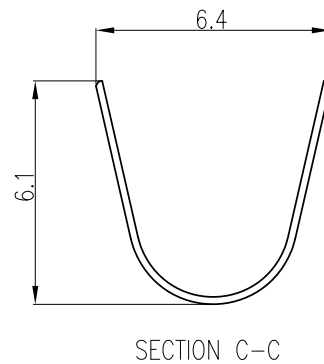
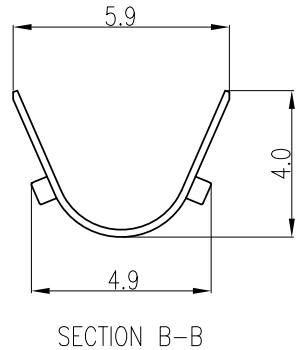
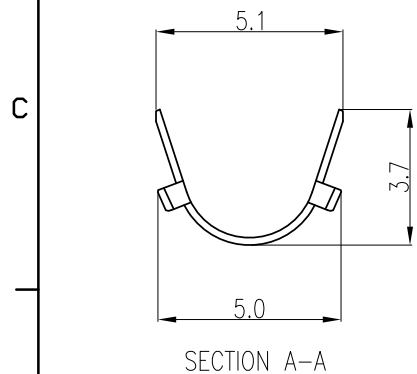

NOTES:

1. MATERIAL: PHOSPHOR BRONZE
2. FINISH: MATTE TIN PLATED OVERALL
3. WIER SIZE RANGE : AWG#18*3-AWG#18*5.
INSULATION O.D: 4.80mm (max)

| | | | | | |
|-------------------------------|--------------------------|-----------------------|--------------------------|---|------|
| TOLERANCE | | PART NO. | | 朝貴電子股份有限公司 CKM ELECTRONICS CO., LTD. | |
| X. | X.XXX ±0.10 | TT-115P | | | |
| X.X | ±0.30 | DRAWING NO. | | TITLE. | |
| X.XX | ±0.20 | C-TT-115P | | TT-115P (TERMINAL) | |
| UNIT: mm | APPROVED BY | CHECKED BY | DRAWN BY | PAGE | REV. |
| | Angus.chen 2023.04.03 | Sun.lee 2023.04.03 | Angel.tong 2023.04.03 | 1 OF 2 | C |
| DWG TYPE. Customer Drawing | | SCALE | | 5 : 1 | |

| | | | | |
|------|-------------|----------------------------------|------------|------------|
| C | EC-23041497 | CHANGE CARTON SIZE | Angel.tong | 2023.04.03 |
| B | EC-21050887 | SIZE REVISING & INCREASE PACKING | Angel.tong | 2021.05.11 |
| REV. | ECN NO | REVISION RECORD | DRAW | DATE |

RoHS

CUST INFORMATION.

| | | |
|----------|-------------|------|
| PART NO. | DRAWING NO. | REV. |
|----------|-------------|------|

LABEL 1=Q'TY : 2.4K PCS

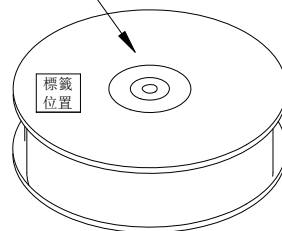
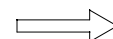
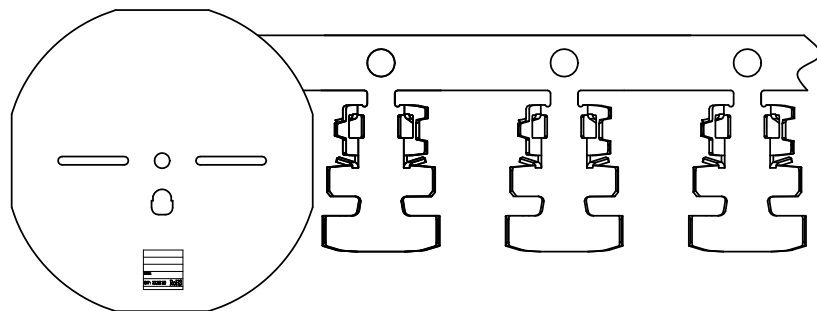
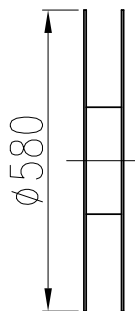

LABEL 2=Q'TY : 24KPCS

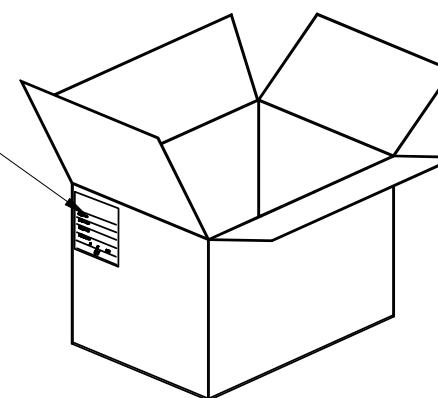
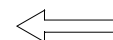
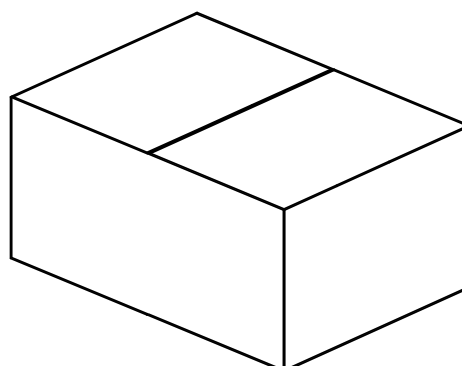

| | |
|---------------------|--------------|
| CARTON SIZE (L*W*H) | LABEL 2 Q'TY |
| 59.7*59.7*33.8cm | 24K PCS |

| | | | | | |
|--|---|-------------------------------------|---|----------------|-----------|
| TOLERANCE X. X.XXX ±0.10 X.X ±0.30 X.XX ±0.20 Angular ±2° | PART NO. TT-115P | | 朝貴電子股份有限公司 CKM ELECTRONICS CO., LTD. | | |
| | DRAWING NO. C-TT-115P | | TITLE. TT-115P (TERMINAL) | | |
| UNIT: mm | APPROVED BY Angus.chen 2023.04.03 | CHECKED BY Sun.lee 2023.04.03 | DRAWN BY Angel.tong 2023.04.03 | PAGE 2 OF 2 | REV. C |
| | DWG TYPE. Customer Drawing | | SCALE 5 : 1 | | |

| | | | | |
|------|-------------|----------------------------------|------------|------------|
| C | EC-23041497 | CHANGE CARTON SIZE | Angel.tong | 2023.04.03 |
| B | EC-21050887 | SIZE REVISING & INCREASE PACKING | Angel.tong | 2021.05.11 |
| REV. | ECN NO | REVISION RECORD | DRAW | DATE |