

1 RoHS

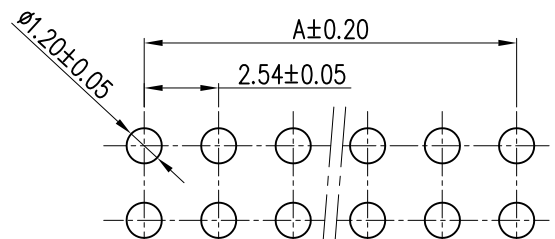

RECOMMENDED PCB LAYOUT (TOP VIEW)

(ALL TOLERANCES ARE ±0.05)
PCB BOARD THK 1.0~1.6mm

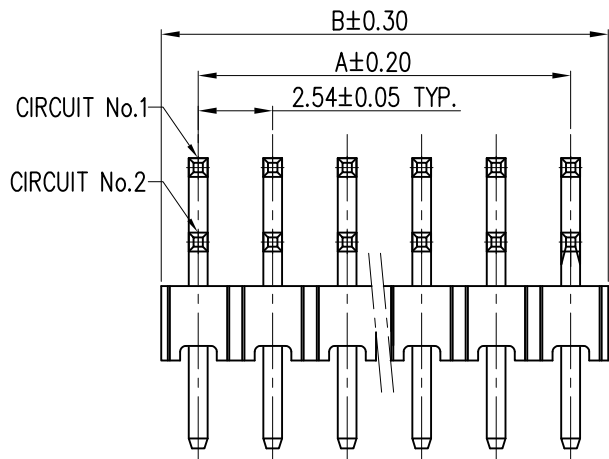
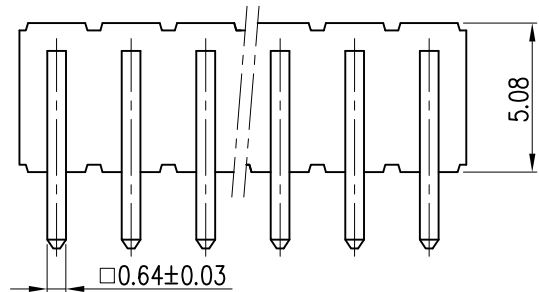
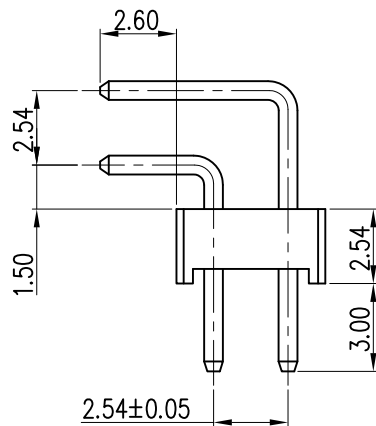

NOTE:

- MATERIAL:
 - INSULATION: LCP UL 94V-0 (BLACK)
 - CONTACT: SQ 0.64mm BRASS
- FINISH: GOLD FLASH PLATING
- RoHS & HALOGEN-FREE COMPLIANCE
- BILL OF PART NO:
 - 2542WR-2CLxXP-CA-LC-HF
 - NO. OF CIRCUITS: 2~30
 - DUAL ROW
- PE BAG PACKAGE
- FOR AVAILABILITY, DELIVERY & MOQ, CONTACT CKM
- DIMENSIONAL

POS	A	B	POS	A	B
4	2.54	5.08	34	40.64	43.18
6	5.08	7.62	36	43.18	45.72
8	7.62	10.16	38	45.72	48.26
10	10.16	12.70	40	48.26	50.80
12	12.70	15.24	42	50.80	53.34
14	15.24	17.78	44	53.34	55.88
16	17.78	20.32	46	55.88	58.42
18	20.32	22.86	48	58.42	60.96
20	22.86	25.40	50	60.96	63.50
22	25.40	27.94	52	63.50	66.04
24	27.94	30.48	54	66.04	68.58
26	30.48	33.02	56	68.58	71.12
28	33.02	35.56	58	71.12	73.66
30	35.56	38.10	60	73.66	76.20
32	38.10	40.64			



A		NEW RELEASE	Jimmy Wang	2019.04.24
REV.	ECN NO	REVISION RECORD	DRAW	DATE

TOLERANCE		PART NO.		朝貴電子股份有限公司 CKM ELECTRONICS CO., LTD.	
X. X.X ±0.30	X.XXX ±0.10	2542WR-2CLxXP-CA-LC-HF			
X.XX ±0.20	Angular ±2°	DRAWING NO.		DESCRIPTION	
		C-2542WR-2CLxXP-CA-LC-HF		2.54mm PITCH RIGHT ANGLE DIP TYPE CONNECTOR	
DWG TYPE.		APPROVED BY	CHECKED BY	DRAWN BY	PAGE
Customer Drawing		Angus Chen	Jimmy Wang	Jimmy Wang	1 OF 2
		2019.04.24	2019.04.24	2019.04.24	SCALE
					4 : 1
					REV.
					A

1 RoHS

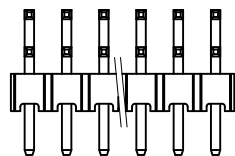

PRODUCT

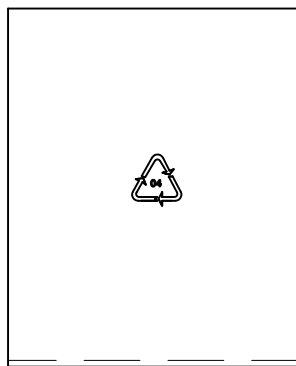
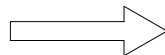

PE BAG

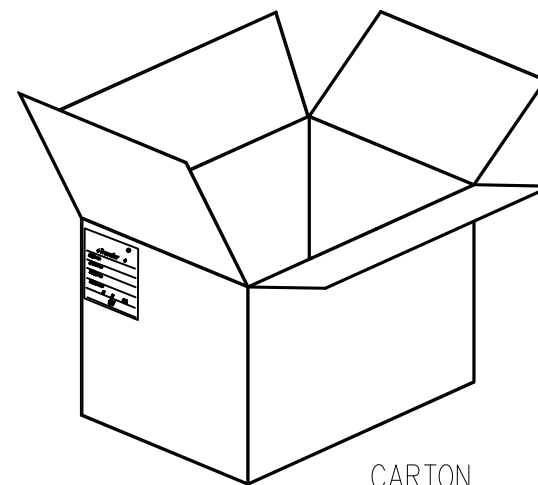
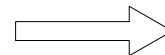

CARTON

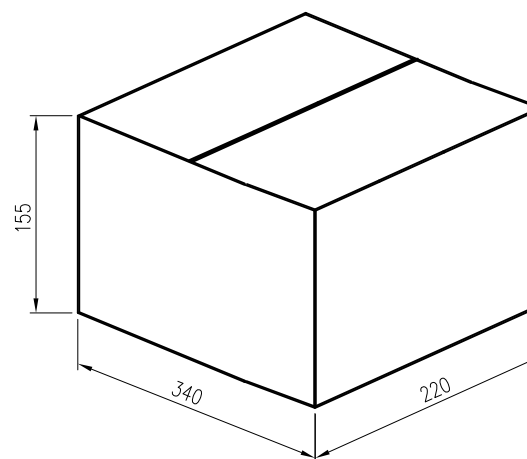

POS	PCS/BAG	POS	PCS/BAG
4	1000	34	1000
6	1000	36	1000
8	1000	38	1000
10	1000	40	1000
12	1000	42	1000
14	1000	44	1000
16	1000	46	1000
18	1000	48	1000
20	1000	50	1000
22	1000	52	1000
24	1000	54	1000
26	1000	56	1000
28	1000	58	1000
30	1000	60	1000
32	1000		

TOLERANCE		PART NO.		朝貴電子股份有限公司 CKM ELECTRONICS CO., LTD.	
X.	X.XXX ±0.10	2542WR-2CLxNP-CA-LC-HF			
X.X	±0.30	DRAWING NO.		DESCRIPTION	
X.XX	±0.20	C-2542WR-2CLxNP-CA-LC-HF		2.54mm PITCH RIGHT ANGLE DIP TYPE CONNECTOR	
UNIT: mm DWG TYPE. Customer Drawing		APPROVED BY	CHECKED BY	DRAWN BY	PAGE
		Angus Chen	Jimmy Wang	Jimmy Wang	2 OF 2
		2019.04.24	2019.04.24	2019.04.24	SCALE
					2 : 1
					REV.
					A

A		NEW RELEASE	Jimmy Wang	2019.04.24
REV.	ECN NO	REVISION RECORD	DRAW	DATE