

RoHS

HF

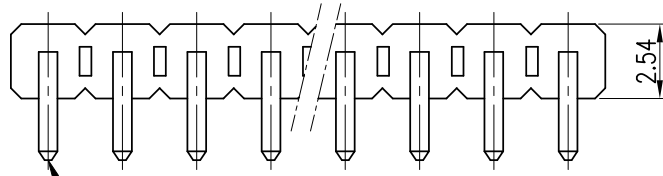

CIRCUIT NO.1

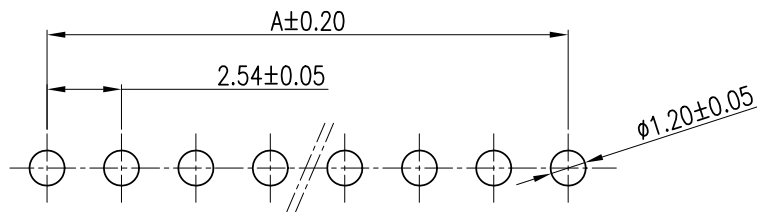
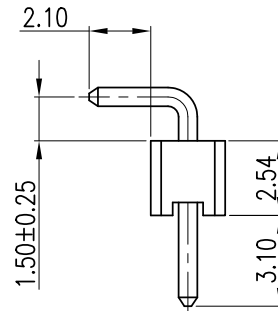
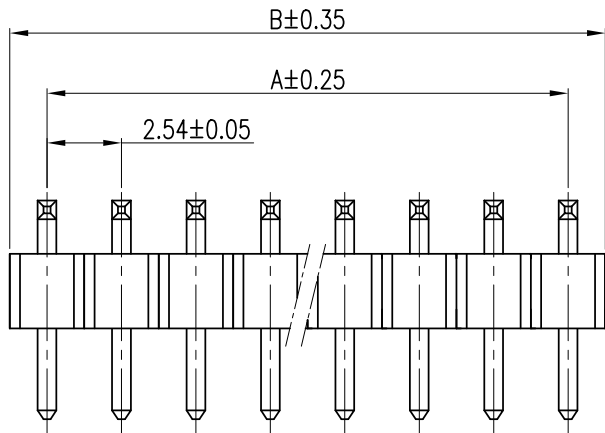

RECOMMENDED PCB LAYOUT(TOP VIEW)

(ALL TOLERANCES ARE ±0.05)
PCB BOARD THK 1.0~1.6mm

NOTE:

1. MATERIAL:

1.1 INSULATION: LCP UL94 V-0 (BLACK)

1.2 CONTACT:SQ 0.64mm BRASS

2. FINISH: GOLD FLASH

3. RoHS & HALOGEN-FREE COMPLIANCE

4. BILL OF PART NO.:

2542WR-1ANxXP-CA-LC-RPC-HF

REEL & TAPE PACKAGE (W/CAP)

NO OF CIRCUITS PER ROW: 3~25

4. FOR AVAILABILITY, DELIVERY & MOQ, CONTACT CKM

5. DIMENSIONAL

POS	A	B	POS	A	B
3	5.08	7.62	14	33.02	35.56
4	7.62	10.16	15	35.56	38.10
5	10.16	12.70	16	38.10	40.64
6	12.70	15.24	17	40.64	43.18
7	15.24	17.78	18	43.18	45.72
8	17.78	20.32	19	45.72	48.26
9	20.32	22.86	20	48.26	50.80
10	22.86	25.40	21	50.80	53.34
11	25.40	27.94	22	53.34	55.88
12	27.94	30.48	23	55.88	58.42
13	30.48	33.02	24	58.42	60.96
			25	60.96	63.50

TOLERANCE		PART NO.		朝貴電子股份有限公司 CKM ELECTRONICS CO., LTD.	
X. X.XXX ±0.10	Angular ±2°	2542WR-1ANxXP-CA-LC-RPC-HF			
X.X ±0.30		DRAWING NO.		TITLE.	
X.XX ±0.20		C-2542WR-1ANxXP-CA-LC-RPC-HF		2.54mm PITCH RIGHT ANGLE DIP TYPE CONNECTOR	
		UNIT:		APPROVED BY	
		mm		Ivan.su 2021.09.16	
DWG TYPE.		CHECKED BY		DRAWN BY	
Customer Drawing		Sun.lee 2021.09.16		Angel.tong 2021.09.16	
		PAGE		REV.	
		1 OF 2		C	
		SCALE			
		4 : 1			

C	EC-21090983	CHANGE PACKING	Angel.tong	2021.09.16
B		ADD 3 & 4 POS INFO.	Jimmy Wang	2020.03.24
REV.	ECN NO	REVISION RECORD	DRAW	DATE

RoHS

HF

PEELING STRENGTH: 10~130GF
PEELING SPEED: 300mm/Min

A

B

C

D

A

B

C

D

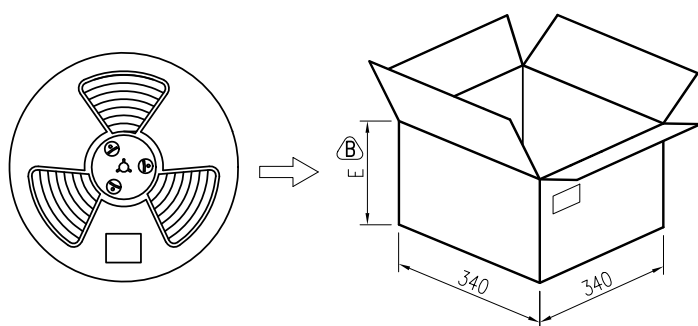
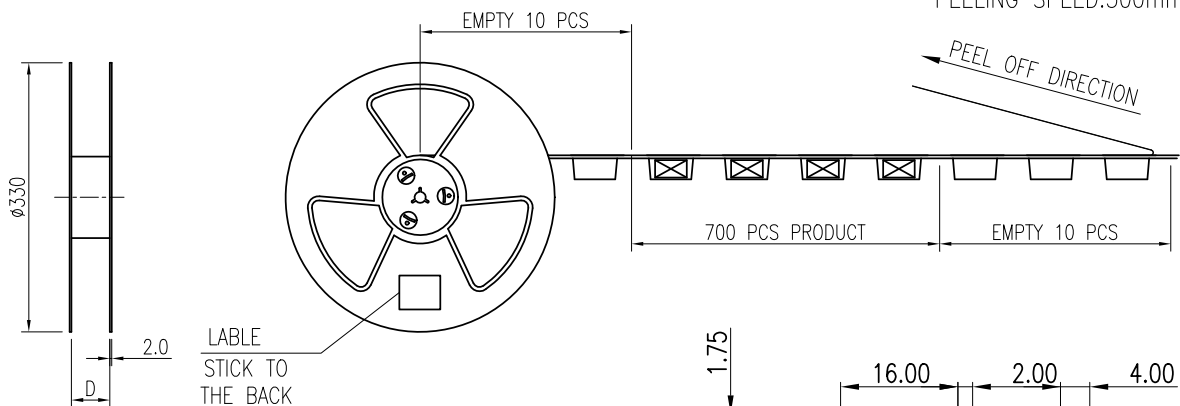

CKM
2021.10.07
研发部

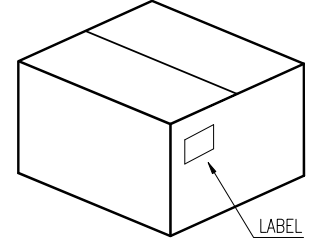

POS	A	B	C	D	E	PCS/REEL	PCS/CARTON
3	24.0		10.2	30.0	120	700	2100
4	32.0	28.4	14.2	38.0	145		2100
5						700	2100
6							
7							
8	44.0	40.4	20.2	50.0	180		
9							
10							
11						700	2100
12							
13							
14	56.0	52.4	26.2	62.0	220		
15							
16							
17						700	2100
18							
19							
20							
21	88.0	84.4	42.2	94.0	280		
22							
23						1400	2100
24							
25							

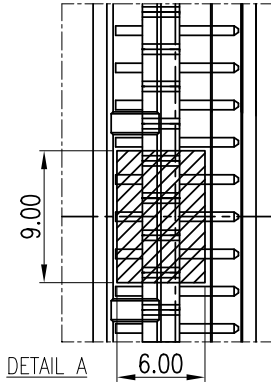
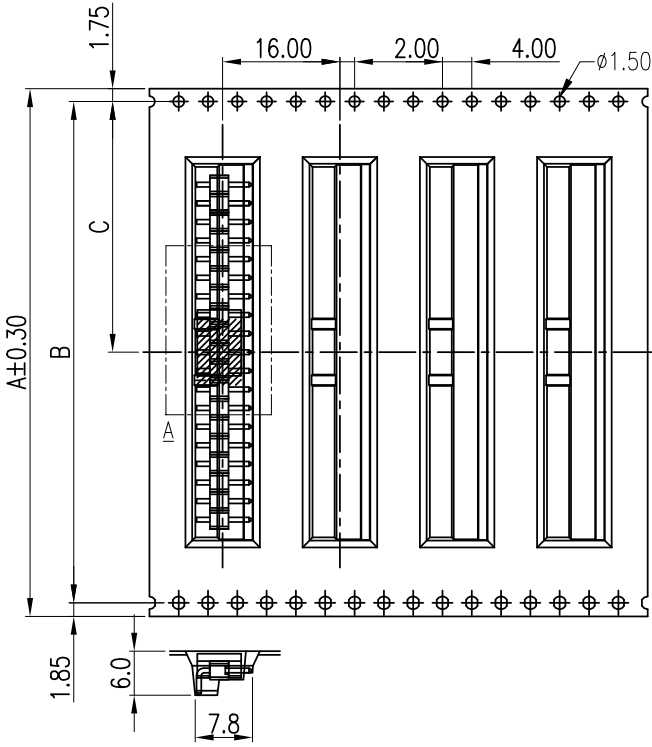

TOLERANCE X. X.XXX ±0.10 X.X ±0.30 X.XX ±0.20 Angular ±2°		PART NO. 2542WR-1ANxXP-CA-LC-RPC-HF		朝貴電子股份有限公司 CKM ELECTRONICS CO., LTD.	
		DRAWING NO. C-2542WR-1ANxXP-CA-LC-RPC-HF		TITLE. 2.54mm PITCH RIGHT ANGLE DIP TYPE CONNECTOR	
UNIT: mm		APPROVED BY Ivan.su 2021.09.16		CHECKED BY Sun.lee 2021.09.16	
DWG TYPE. Customer Drawing		DRAWN BY Angel.tong 2021.09.16		PAGE 2 OF 2 SCALE 4 : 1	
				REV. C	

C	EC-21090983	CHANGE PACKING	Angel.tong	2021.09.16
B		ADD 3 & 4 POS INFO.	Jimmy Wang	2020.03.24
REV.	ECN NO	REVISION RECORD	DRAW	DATE