



PRODUCT SPECIFICATION

CKM 3962 SERIES

WIRE TO BOARD 3.96mm PITCH CONNECTOR

INDEX

1. SCOPE.....	P2
2. APPLICABLE DOCUMENTS.....	P2
3. REQUIREMENTS.....	P2~4
4. QUALITY ASSURANCE PROVISIONS.....	P5~6

REVISION HISTORY:

REV	REVISION DESCRIPTION	DATE	CREATED/REVISED
A	NEW RELEASE	2006.04.03	
B	UPGRADE THE FORM	2013.10.20	Qing gang yang
C	UPDATE OPERATING TEMPERATURE	2015.10.27	Guo xiang Jiang
D	UPGRADE THE FORM	2016.11.7	Jimmy Wang
E	UPGRADE THE FORM	2017.06.12	Jimmy Wang

<b>REVISION:</b> <b>E</b>	<b>ECR/ECN INFORMATION:</b> EC No.: DATE: 2017/06/16	<b>TITLE:</b> 3.96mm PITCH CONNECTOR		<b>SHEET No.</b> 1 of 6
<b>DOCUMENT NUMBER:</b> <b>PS-3962-001</b>		<b>CREATED/REVISED</b> Qing gang yang	<b>CHECKED BY</b> Sun Lee	<b>APPROVED BY</b> Angus Chen



## 1. SCOPE

This product specification covers performance, tests and quality requirements for **3962 Connector System**. When tests are performed on subject product line, procedures specified in Figure 1 shall be used. All inspections shall be performed using the applicable product drawing.

## 2. APPLICABLE DOCUMENTS

The following documents form a part of this specification to the extent specified herein. Unless otherwise specified, the latest edition of the document applies. In the event of conflict between the requirements of the specification and the product drawing, the product drawing shall take precedence. In the event of conflict between the requirements of this specification and the referenced documents, this specification shall take precedence.

### 2.1. APPLICABLE DOCUMENTS AND SPECIFICATIONS

EIA-364  
UL-94 Flammability

## 3. REQUIREMENTS

### 3.1 Design and Construction

Product shall be of the design, construction and physical dimensions specified on the applicable product drawing.

### 3.2 Product Shape, Dimensions and Materials

Materials used in the construction of this product shall be as specified on the applicable product drawing.

### 3.3 Ratings

1. Voltage rating: 250V~600V(Only Void even Pin) AC/DC.
2. Current rating: 7A~10A(Only 2 Circuits, Void Pin), See Figure 4 for applicable current carrying capability. Maximum rated current that can be carried by this product is limited by maximum operating temperature of the housings (105°C) and temperature rise of the housings (30°C). Variables to be considered for each application are: wire size, connector size, contact material, ambient temperature, and printed circuit board design.
3. Temperature range: -25 to 105°C
4. Applicable wire: AWG #14 to #22

### 3.4 Performance and Test Description.

Product is designed to meet the electrical, mechanical and environmental performance requirements specified in Figure 1.

Unless otherwise specified, all tests shall be performed at ambient environmental conditions.

### 3.5 Test Requirements and Procedures Summary

Test Description	Requirement	Procedure
Initial examination of product.	Meets requirements of product drawing and Application	Visual and dimensional (C of C) inspection per product drawing. (EIA-364-18)
Final examination of product.	Meets visual requirements.	Visual inspection. (EIA-364-18)
<b>ELECTRICAL</b>		
Low Level Contact Resistance (LLCR).	10 milliohms maximum initial. 20 milliohms maximum final.	Subject specimens to 100milliamperes maximum and 20millivolts maximum open circuit voltage. See Figure 3. (EIA-364-23)
<b>REVISION:</b> <b>E</b>	<b>ECR/ECN INFORMATION:</b> EC No.: DATE: 2017/06/16	<b>TITLE:</b> 3.96mm PITCH CONNECTOR
<b>DOCUMENT NUMBER:</b> <b>PS-3962-001</b>		<b>CREATED/REVISED</b> Qing gang yang
<b>CHECKED BY</b> Sun Lee		<b>APPROVED BY</b> Angus Chen
<b>SHEET No.</b> 2 of 6		



朝貴電子股份有限公司

CKM ELECTRONICS CO., LTD.

Insulation resistance.	1000MΩ minimum initial. 500MΩ minimum final.	500 volts DC, 2 minute hold. Test between adjacent contacts. (EIA-364-21)
Withstanding voltage.	One minute hold with no breakdown or flashover. 1.3mA maximum leakage current.	1500 volts AC at sea level. Test between adjacent contacts. (EIA-364-20, Condition I)
Temperature rise vs. current.	30°C maximum temperature rise at specified current.	Stabilize at a single current level until 3 readings at 5 minute intervals are within 1°C. See Figure 4. (EIA-364-70, Method 1)

**MECHANICAL**

Solder ability dip test.	Solder able area shall have a minimum of 95% solder coverage.	
Resistance to Wave Soldering Heat	No physical damage shall occur	Subject product mounted on printed circuit board to solder bath at 260±5°C for 5±1ses
Random vibration.	1) No discontinuities of 1 microsecond or longer duration. 2) Contact resistance: 30 milliohms maximum 3) No physical damage.	Subject mated specimens to 3.10G's rms between 20 to 500 Hz, Amplitude: 1.52mm, Test Duration: 15 minutes each axis. (EIA-364-28, Test Condition VII, Condition Letter D)
Mechanical shock.	No discontinuities of 1 microsecond or longer duration. See Note.	Subject mated specimens to 30 G's half-sine shock pulses of 11 milliseconds duration. Three shocks in each direction applied along 3 mutually perpendicular planes, 18 total shocks. (EIA-364-27, Method H)
Durability.	See Note.	Manually mate and un mate specimens with companion headers for 15 cycles at a maximum rate of 500 cycles per hour. (EIA-364-9)
Mating force.	6N maximum per contact.	Measure force necessary to mate specimens with companion headers a distance of 5.08 mm from point of initial contact at a maximum rate of 12.7mm per minute. ( EIA-364-13)
Un mating force.	1.5N minimum per contact.	Measure force necessary to un mate specimens from companion headers at a maximum rate of 12.7mm per minute. (EIA-364-13)
Crimp strength	See 5.0. Crimping Specification:	Determine crimp tensile at a rate of 25.4 mm per minute. (EIA-364-8)
Contact retention.	1.5kg minimum	Apply axial load at a rate of 4.4 N per second and hold for 6 seconds. (EIA-364-29)

**ENVIRONMENTAL**

Thermal shock.	See Note.	Subject mated specimens to 10cycles between -55 and 105°C with 30 minute dwells at temperature extremes and 1 minute transition between temperatures. (EIA-364-32 Test Condition VII)
----------------	-----------	---

<b>REVISION:</b> <b>E</b>	<b>ECR/ECN INFORMATION:</b> EC No.: DATE: 2017/06/16	<b>TITLE:</b> 3.96mm PITCH CONNECTOR	<b>SHEET No.</b> 3 of 6
<b>DOCUMENT NUMBER:</b> <b>PS-3962-001</b>		<b>CREATED/REVISED</b> Qing gang yang	<b>CHECKED BY</b> Sun Lee
		<b>APPROVED BY</b> Angus Chen	



Humidity / temperate cycling.	See Note.	Subject specimens to 10 cycles (10days) between 25 and 65°C at 80 to100% RH. (EIA-364-31, Method III)
Temperature life.	See Note.	Subject mated specimens to 105°C for 500 hours (EIA-364-17, Method A, Test Condition 4, Test Time Condition C)

Figure 1(End)

**NOTE**

Shall meet visual requirements, show no physical damage, and meet requirements of additional tests as specified in the Product Qualification and Requalification Test Sequence shown in Figure2.

Test or Examination	Test Group (a)				
	1	2	3	4	5
	Test Sequence (b)				
Initial examination of product	1	1	1	1	1
LLCR	3.7	2.6			
Insulation resistance			2.5		
Withstanding voltage			3.6		
Temperature rise vs current		3			
Solder ability dip test				2	
Random vibration	5				
Mechanical shock	6				
Durability	4				
Mating force	2				
Un mating force	8				
Crimp tensile					2
Contact retention			7		
Thermal shock			4		
Humidity/temperature cycling		4( C )			
Temperature life		5			
Final examination of product	9	7	8	3	3

Figure 2

**NOTE:**

- (a)See paragraph 4.1.A.
- (b)Numbers indicate sequence in which tests are performed.
- (c)Precondition specimens with 10 durability cycles.

<b>REVISION:</b> <b>E</b>	<b>ECR/ECN INFORMATION:</b> EC No.: DATE: 2017/06/16	<b>TITLE:</b> 3.96mm PITCH CONNECTOR	<b>SHEET No.</b> 4 of 6
<b>DOCUMENT NUMBER:</b> <b>PS-3962-001</b>	<b>CREATED/REVISED</b> Qing gang yang	<b>CHECKED BY</b> Sun Lee	<b>APPROVED BY</b> Angus Chen



**4. QUALITY ASSURANCE PROVISIONS**

4.1 Qualification Testing

A. Specimen Selection

Specimens shall be prepared in accordance with applicable Instruction Sheets and shall be selected at random from current production. Test groups 1, 2, 3 and 5 shall each consist of a minimum of 5 specimens with a minimum of 30 data points. Test group 4 shall consist of a minimum of 5 specimens with a minimum of 30 header posts

B. Test Sequence

Qualification inspection shall be verified by testing specimens as specified in Figure 2.

4.2 Requalification Testing

If changes significantly affecting form, fit or function are made to the product or manufacturing process, product assurance shall coordinate requalification testing, consisting of all or part of the original testing sequence as determined by development/product, quality and reliability engineering.

4.3 Acceptance

Acceptance is based on verification that the product meets the requirements of Figure 1. Failures attributed to equipment, test setup or operator deficiencies shall not disqualify the product. If product failure occurs, corrective action shall be taken and specimens resubmitted for qualification. Testing to confirm corrective action is required before resubmittal.

4.4 Quality Conformance Inspection

The applicable quality inspection plan shall specify the sampling acceptable quality level to be used. Dimensional and functional requirements shall be in accordance with the applicable product drawing and this specification.

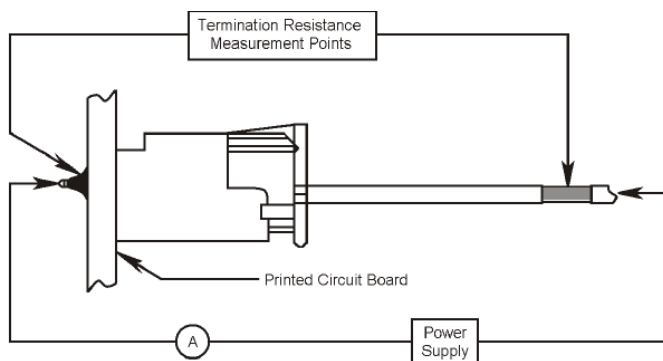

**Figure 3**  
**LLCR Measurement Points**

<b>REVISION:</b> <b>E</b>	<b>ECR/ECN INFORMATION:</b> EC No.: DATE: 2017/06/16	<b>TITLE:</b> 3.96mm PITCH CONNECTOR	<b>SHEET No.</b> 5 of 6
<b>DOCUMENT NUMBER:</b> <b>PS-3962-001</b>		<b>CREATED/REVISED</b> Qing gang yang	<b>CHECKED BY</b> Sun Lee
		<b>APPROVED BY</b> Angus Chen	

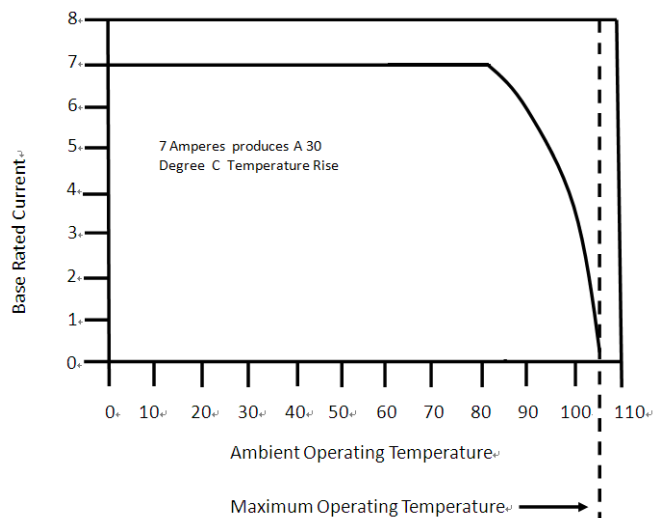

Figure 4 (Current Rating)

**NOTE:**

To determine acceptable current carrying capacity for percentage connector loading and wire gage indicated, use the Multiplication Factor (F) from the above chart and multiply it times the Base rated Current for a single circuit at the maximum ambient operating temperature shown in Figure 4.

**5.0. Crimping Specification:**

Fix the crimped terminal, apply axial pull out force on the wire at a constant speed of 25±3mm/minute. (Based upon JIS C5402 6.22)

3962T0X-XX				
Wire Size(AWG)		#18	#20	#22
1. CONDUCTOR (mm)	CRIMP VIDTH	2.0±0.10		
	CRIMP HEIGHT	1.13~1.22	1.03~1.12	0.93~1.02
2. INSULATION (mm)	CRIMP VIDTH	2.80		
	CRIMP HEIGHT	2.54	2.34	2.14
CRIMP STRENGTH		9.0Kgf (MIN)	6.0Kgf (MIN)	4.0Kgf (MIN)
3962T2X-XX				
Wire Size(AWG)		#14	#16	#18
1. CONDUCTOR (mm)	CRIMP VIDTH	2.0±0.10		
	CRIMP HEIGHT	1.80~1.86	1.72~1.79	1.20~1.30
2. INSULATION (mm)	CRIMP VIDTH	2.85		
	CRIMP HEIGHT	3.25	3.07	2.65
CRIMP STRENGTH		9.0Kgf (MIN)	9.0Kgf (MIN)	9.0Kgf (MIN)

<b>REVISION:</b> <b>E</b>	<b>ECR/ECN INFORMATION:</b> EC No.: DATE: 2017/06/16	<b>TITLE:</b> 3.96mm PITCH CONNECTOR	<b>SHEET No.</b> 6 of 6
<b>DOCUMENT NUMBER:</b> <b>PS-3962-001</b>	<b>CREATED/REVISED</b> Qing gang yang	<b>CHECKED BY</b> Sun Lee	<b>APPROVED BY</b> Angus Chen