

RoHS

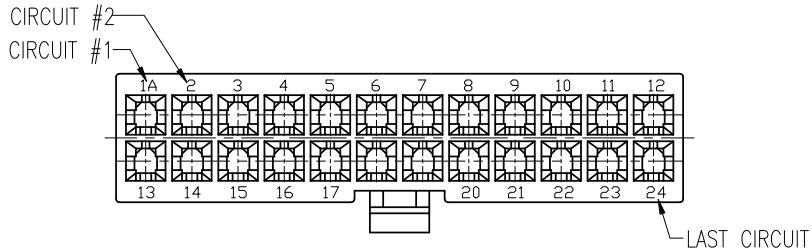

CUST INFORMATION.

PART NO.	DRAWING NO.	REV.
----------	-------------	------



NOTE:
 1. MATERIAL: NYLON 66
 2. BILL OF PART NO.
 CKM4203-HM-XX-X-X
 CIRCUIT: 2~24 POS

MATERIAL:
 1=NYLON 66 UL 94V-0
 2=NYLON 66 UL 94V-2

COLOR:
 N=NATURAL
 B=BLACK
 C=RED
 G=BLUE
 J=GRAY

3. RoHS & HF COMPLIANCE
 4. DIMENSIONAL & ORDER INFORMATION:

POS	A	B	C	PCS/BAG
02		5.4	3.30	1000
04	4.2	9.6		1000
06	8.4	13.8		1000
08	12.6	18.0		1000
10	16.8	22.2		1000
12	21.0	26.4		1000
14	25.2	30.6	3.60	1000
16	29.4	34.8		500
18	33.6	39.0		500
20	37.8	43.2		500
22	42.0	47.4		400
24	46.2	51.6		400

5. FOR CAVALABILITY, DELIVERY & MOQ, CONTACT CKM

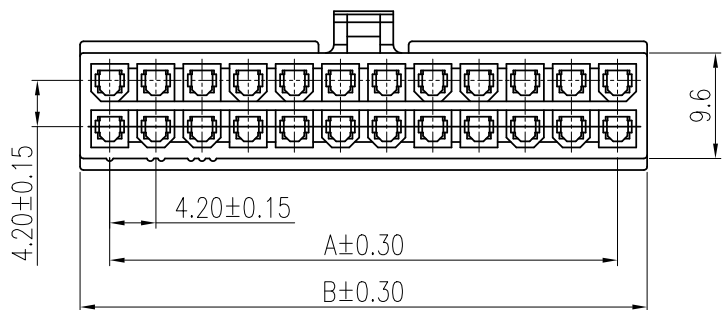
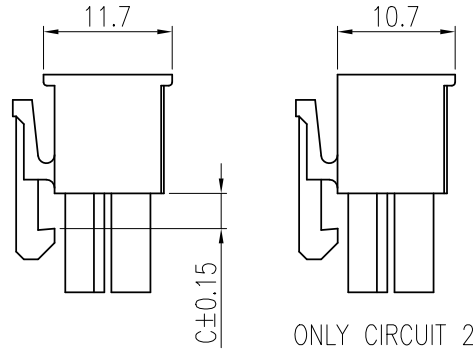
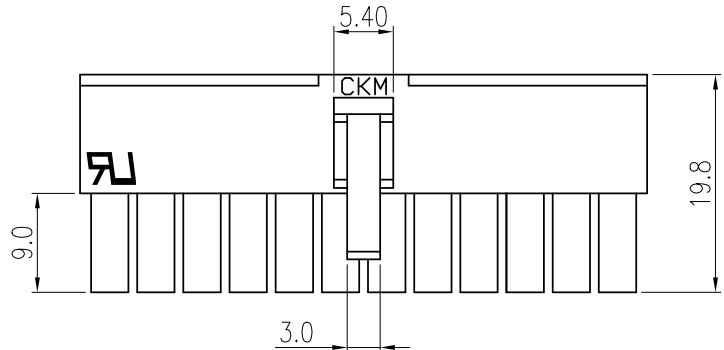

TOLERANCE		PART NO.		朝貴電子股份有限公司 CKM ELECTRONICS CO., LTD.	
X.	X.XXX ±0.10	CKM4203-HM-XX-X-X		TITLE.	
X.X	±0.30	DRAWING NO.		4.2mm PITCH CRIMP TERMINAL SOCKET	
X.XX	±0.20	C-CKM4203-HM-XX-X-X		APPROVED BY	
UNIT: mm		CHECKED BY		DRAWN BY	
DWG TYPE.		Angus.Chen		GuoXiang.Jiang	
Customer Drawing		2023.04.06		2023.04.06	
		PAGE		REV.	
		1 OF 2		B	
		SCALE			
		3 : 1			

B	EC-23041501	ADD RED/BLUE/GRAY OPTION	GuoXiang.Jiang	2023.04.06
A		NEW RELEASE	GuoXiang.Jiang	2016.09.21
REV.	ECN NO	REVISION RECORD	DRAW	DATE

RoHS

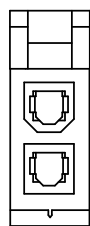

CIRCUIT 2

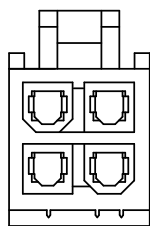

CIRCUIT 4

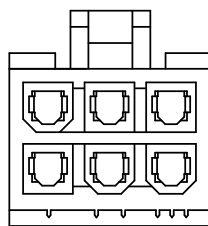

CIRCUIT 6

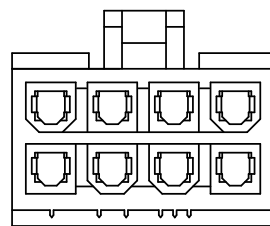

CIRCUIT 8

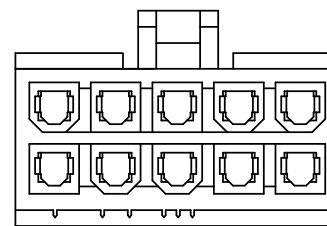

CIRCUIT 10

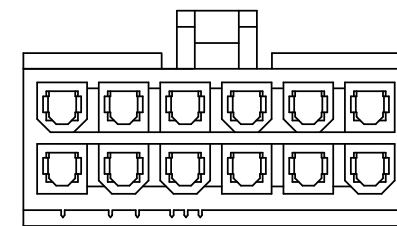

CIRCUIT 12

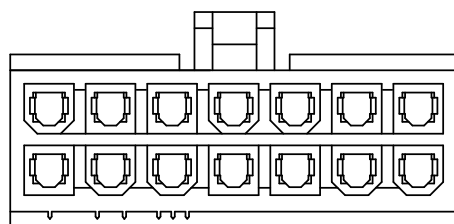

CIRCUIT 14

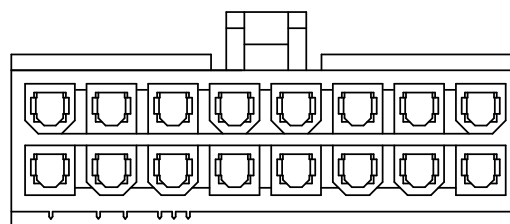

CIRCUIT 16

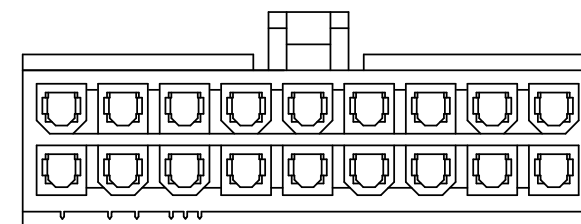

CIRCUIT 18

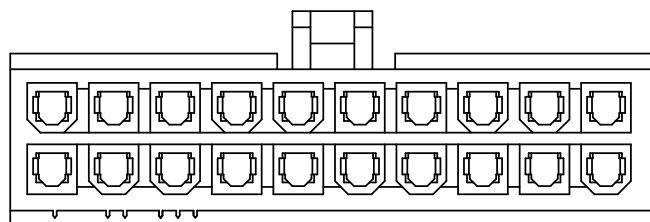

CIRCUIT 20

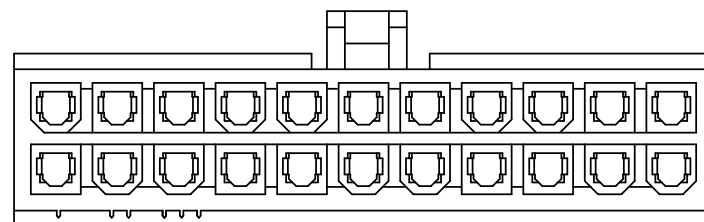

CIRCUIT 22

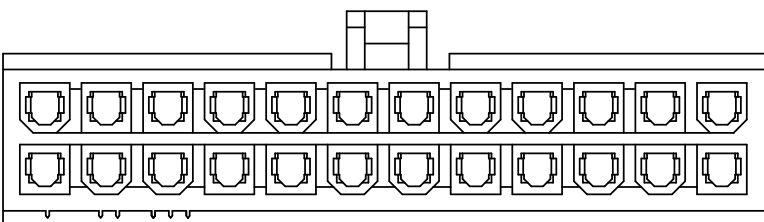

CIRCUIT 24



TOLERANCE	
X.	X.XXX ±0.10
X.X ±0.30	
X.XX ±0.20	Angular ±2°
UNIT:	mm
DWG TYPE. Customer Drawing	

PART NO. CKM4203-HM-XX-X-X	
DRAWING NO. C-CKM4203-HM-XX-X-X	
APPROVED BY Angus.Chen 2023.04.06	CHECKED BY Sun.Lee 2023.04.06

朝貴電子股份有限公司 CKM ELECTRONICS CO., LTD.	
DESCRIPTION 4.2mm PITCH CRIMP TERMINAL SOCKET	
DRAWN BY GuoXiang.Jiang 2023.04.06	PAGE 2 OF 2
SCALE 2 : 1	REV. B

B	EC-23041501	ADD RED/BLUE/GRAY OPTION	GuoXiang.Jiang	2023.04.06
A		NEW RELEASE	GuoXiang.Jiang	2016.09.21
REV.	ECN NO	REVISION RECORD	DRAW	DATE