

RoHS

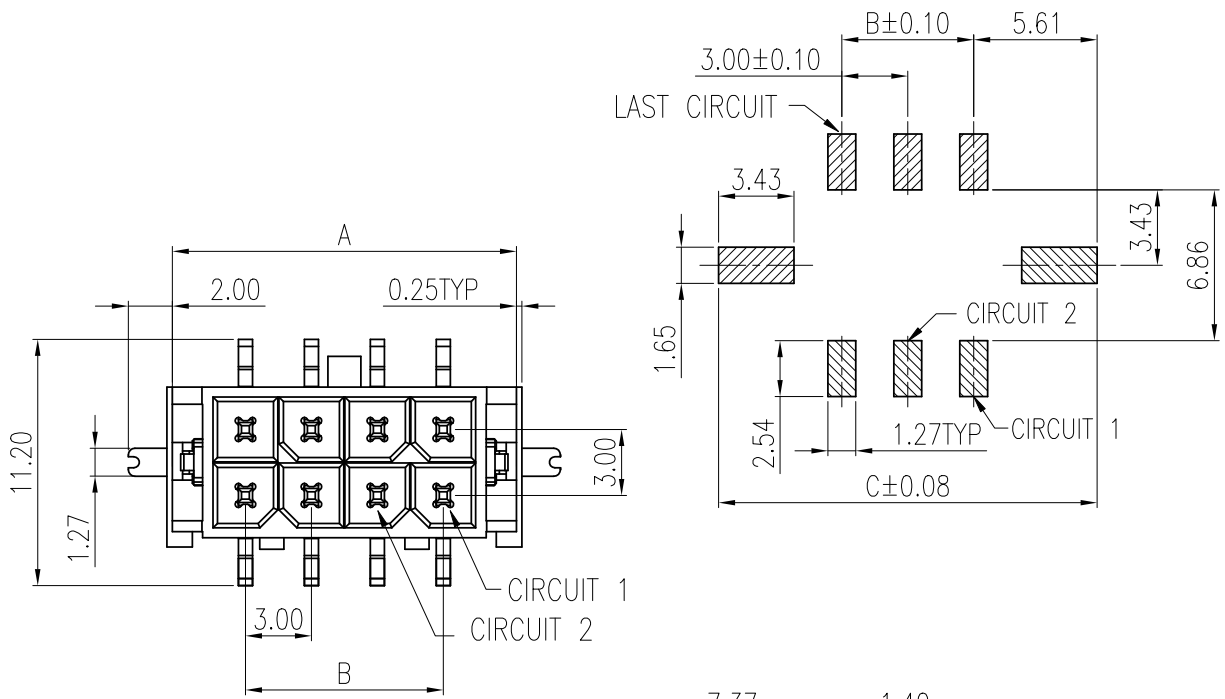

A
B
C
D

A
B
C
D



NOTES:

- MATERIAL SPECIFICATION:
 - 1.1 INSULATION: LCP, UL 94V-0
 - 1.2 CAP: LCP, UL 94V-0, COLOR: BLACK.
 - 1.3 CONTACT: 0.64mm THICKNESS BRASS
 - 1.4 SOLDER TAB: 0.40mm THICKNESS BRASS
- FINISH:
 - CONTACT: MATTE-TIN OR GOLD PLATING (CONTACT AREA)
 - SOLDER AREA: MATTE TIN
- RoHS & HALOGEN FREE COMPLIANT
- BILL OF PART NO:
 - 3001WVS-2xXP-XX-XX-B-XX-HF
 - No. OF CIRCUITS: 1~12
 - FINISH: A=MATTE-TIN PLATING
 - C0=GOLD FLASH PLATING
 - C4=15u" GOLD PLATING
 - C7=30u" GOLD PLATING
 - OPTION: BLANK=W/CAP OR NC=W/O CAP
 - INSULATION: BLANK=LCP E130i OR LC=LCP E471i
 - COLOR: BLANK=NATURAL OR A=BLACK
- FOR FINISH, COLOR, AVAILABILITY, DELIVERY & MOQ, CONTACT CKM.
- DIMENSIONAL

POS	A	B	C	D
2x1	6.65	--	11.20	6.74
2x2	9.65	3.00	14.20	
2x3	12.65	6.00	17.20	1.60
2x4	15.65	9.00	20.20	
2x5	18.65	12.00	23.20	
2x6	21.65	15.00	26.20	
2x7	24.65	18.00	29.20	
2x8	27.65	21.00	32.20	
2x9	30.65	24.00	35.20	
2x10	33.65	27.00	38.20	
2x11	36.65	30.00	41.20	
2x12	39.65	33.00	44.20	

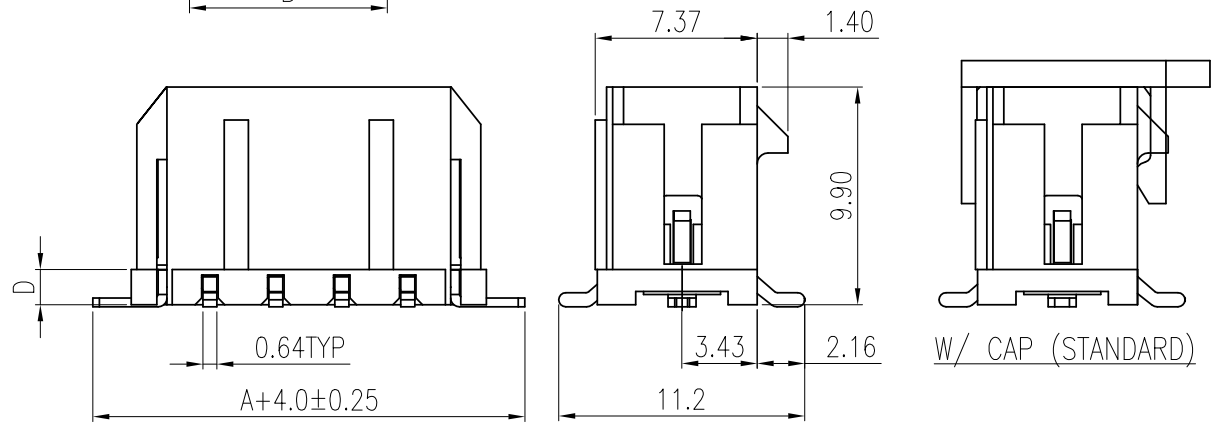

TOLERANCE X. X.XXX ±0.10 X.X ±0.30 X.XX ±0.20 Angular ±2°		PART NO. 3001WVS-2xXP-XX-XX-B-XX-HF		朝貴電子股份有限公司 CKM ELECTRONICS CO., LTD.	
UNIT: mm		DRAWING NO. C-3001WVS-2xXP-XX-XX-B-XX-HF		DESCRIPTION 3.0mm PITCH SMT VERTICAL TYPE CONNECTOR	
DWG TYPE. Customer Drawing		APPROVED BY Ivan.Su 2021.11.02	CHECKED BY Sun.Lee 2021.11.02	DRAWN BY Rock 2021.11.02	PAGE 1 OF 3 SCALE 3 : 1
				REV. A	

A		NEW RELEASE	Rock	2021.11.02
REV.	ECN NO	REVISION RECORD	DRAW	DATE

1

2

3

4

5

6

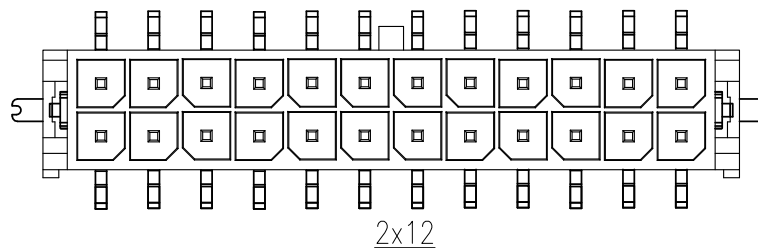
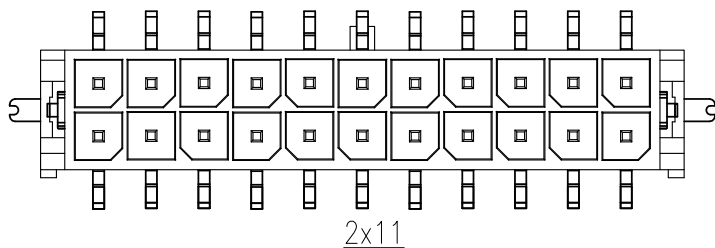
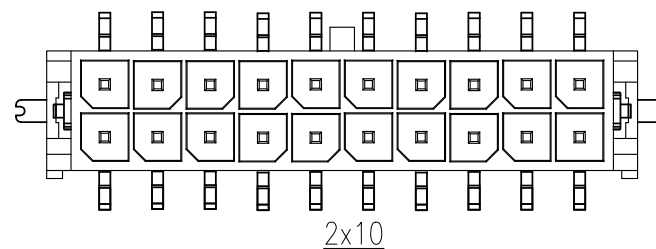
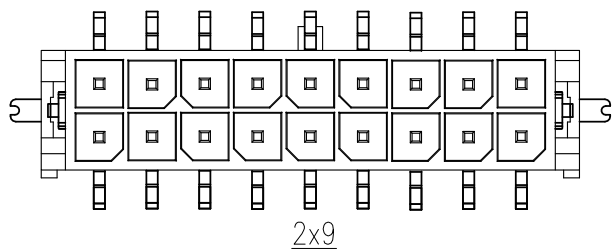
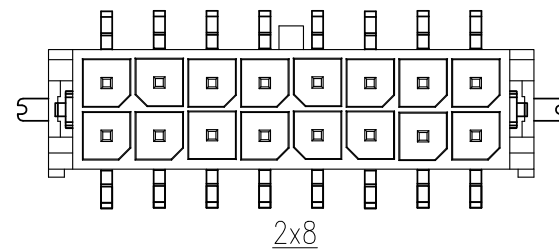
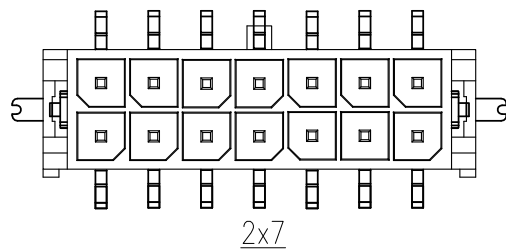
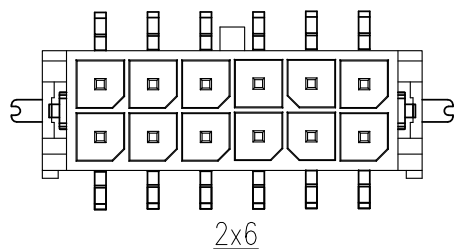
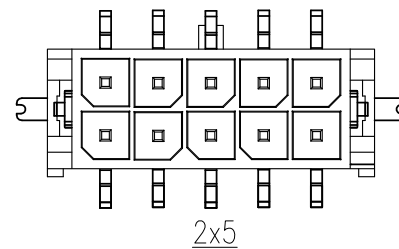
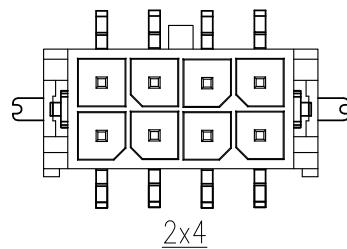
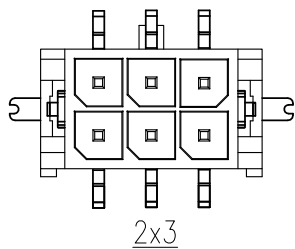
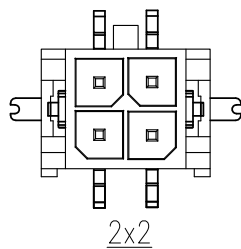
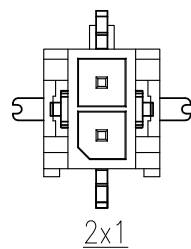

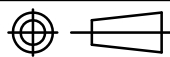
TOLERANCE		PART NO.		 朝貴電子股份有限公司 CKM ELECTRONICS CO., LTD.	
X. X.XXX ±0.10	Angular ±2°	3001WVS-2xXP-XA-XX-B-XX-HF			
X.X ±0.30		DRAWING NO.		DESCRIPTION	
X.XX ±0.20		C-3001WVS-2xXP-XA-XX-B-XX-HF		3.0mm PITCH SMT VERTICAL TYPE CONNECTOR	
 UNIT: mm DWG TYPE. Customer Drawing		APPROVED BY	CHECKED BY	DRAWN BY	PAGE
		Ivan.Su 2021.11.02	Sun.Lee 2021.11.02	Rock 2021.11.02	2 OF 3
				SCALE	A
				3 : 1	

A		NEW RELEASE	Rock	2021.11.02
REV.	ECN NO	REVISION RECORD	DRAW	DATE

1

2

3

4

5

6

QMI-P12-05-01

RoHS

HF

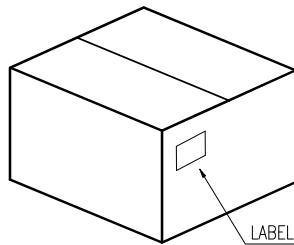
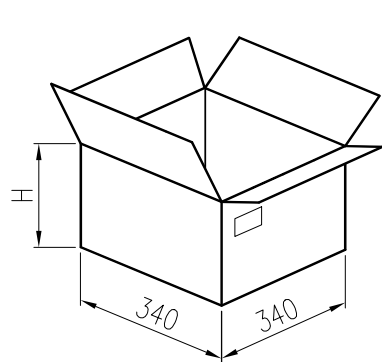
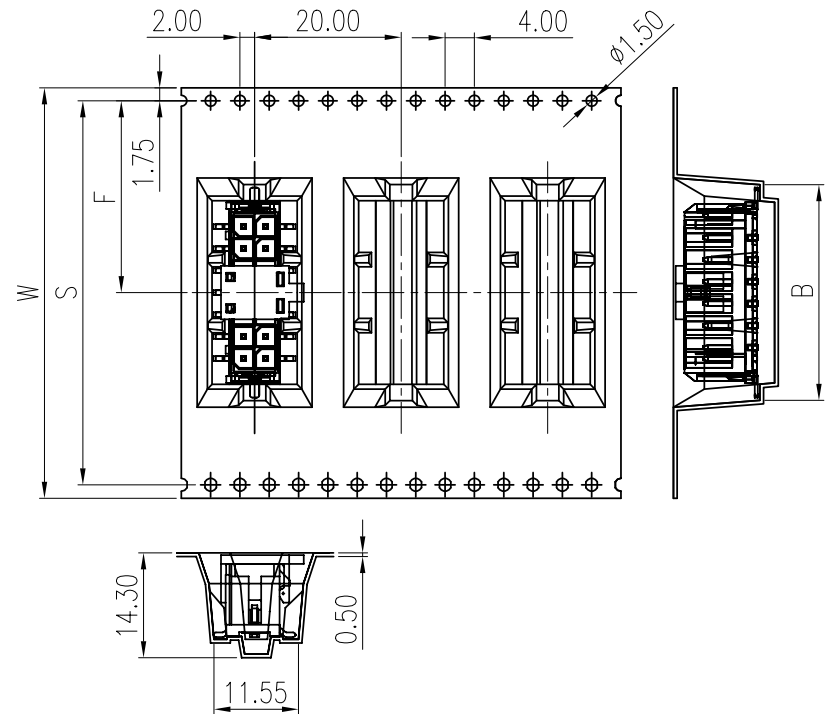
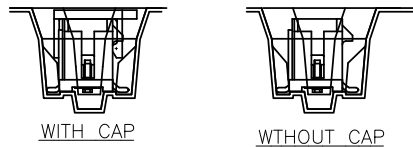
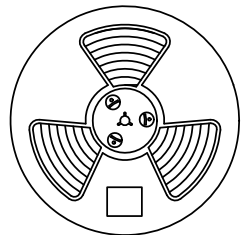
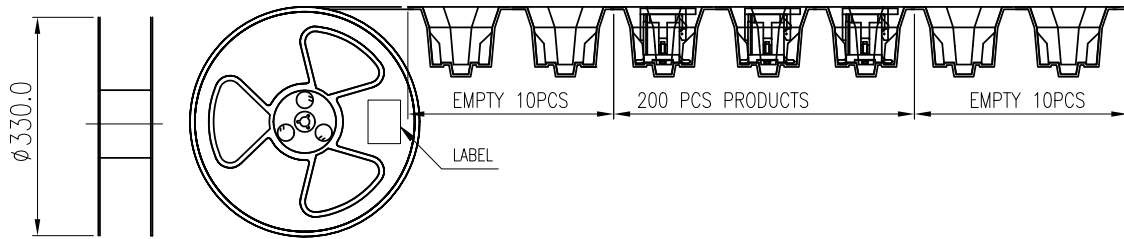

CKM
2021.11.03
研发部

POS	W	S	F	B	H	PCS/REEL	REELS/CARTON	PCS/CARTON
2x1	24.0	--	10.2	13.3		200	9	1800
2x2								
2x3								
2x4	44.0	40.4	20.2	25.3	220		5	1000
2x5								
2x6								
2x7								
2x8								
2x9	56.0	52.4	26.2	37.3	280		3	600
2x10								
2x11								
2x12								

TOLERANCE		PART NO.		朝貴電子股份有限公司 CKM ELECTRONICS CO., LTD.	
X.	X.XXX ±0.10	3001WVS-2xXP-XA-XX-B-XX-HF			
X.X	±0.30	DRAWING NO. C-3001WVS-2xXP-XA-XX-B-XX-HF		DESCRIPTION 3.0mm PITCH SMT VERTICAL TYPE CONNECTOR	
X.XX	±0.20				
UNIT: mm		DWG TYPE. Customer Drawing		DRAWN BY Rock 2021.11.02	
				PAGE 3 OF 3	
				SCALE 3 : 1	
				REV. A	

A		NEW RELEASE	Rock	2021.11.02
REV.	ECN NO	REVISION RECORD	DRAW	DATE

1

2

3

4

5

6 QMI-P12-05-01