

PROPOSAL

RoHS

HF

CUST INFORMATION.

PART NO.	DRAWING NO.	REV.
----------	-------------	------

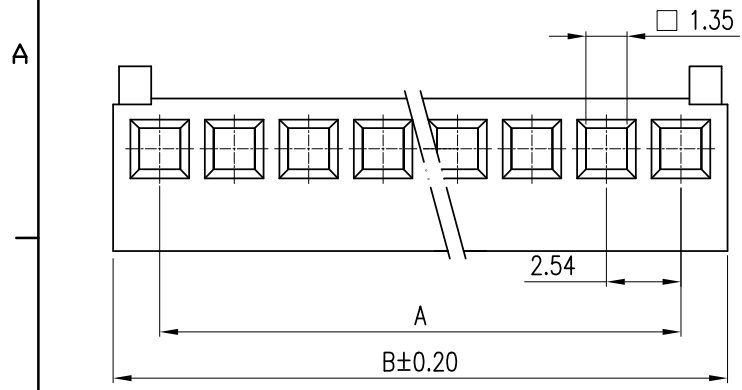

- MATERIAL: NYLON 66 UL94 V-2
- RoHS & HF COMPLIANCE
- BILL OF PART NO.
2541H-XP-X-XX-XX-HF
 - BLANK= W/O FRICTION LOCK
 - FL= W/ FRICTION LOCK
 - BLANK= W/ "CKM" LOGO
 - NS= W/O "CKM" LOGO
 - COLOR: BLANK(NATURAL) OR A THRU M
- FOR COLOR, AVAILABILITY, DELIVERY & MOQ, CONTACT CKM
- DIMENSIONAL

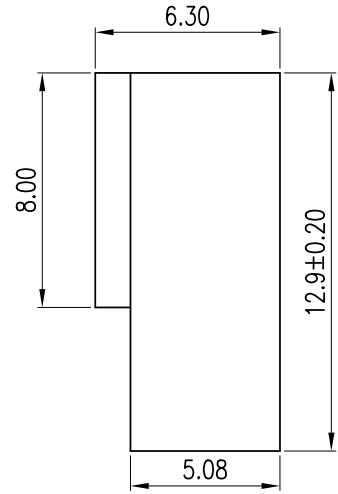
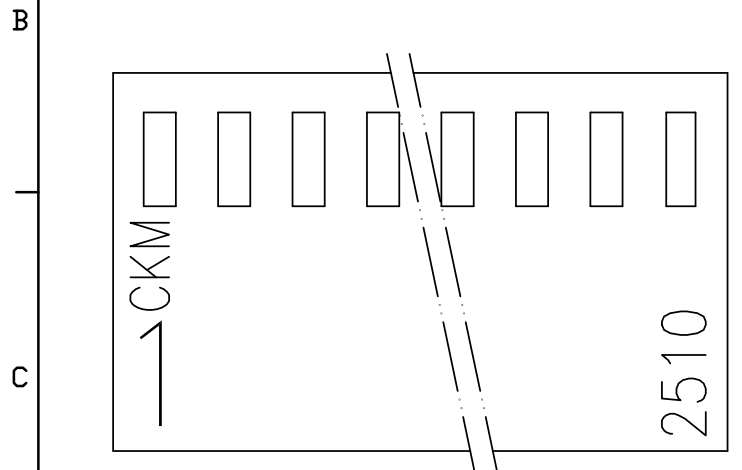

POS	A	B	11	25.40	28.6
2	2.54	5.7	12	27.94	31.1
3	5.08	8.2	13	30.48	33.6
4	7.62	10.8	14	33.02	36.2
5	10.16	13.3	15	35.56	38.7
6	12.70	15.9	16	38.10	41.3
7	15.24	18.4	17	40.64	43.8
8	17.78	20.9	18	43.18	46.3
9	20.32	23.5	19	45.72	48.9
10	22.86	26.0	20	48.26	51.4

COLOR CODE	
BLANK	NATURAL
A	BLACK
B	BROWN
M	MILKY YELLOW

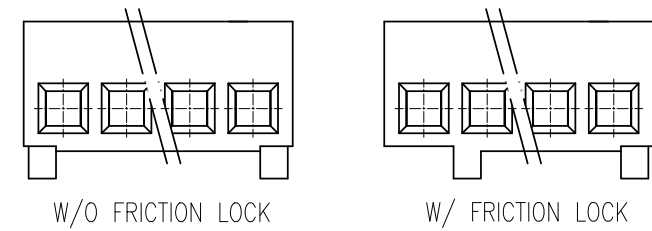
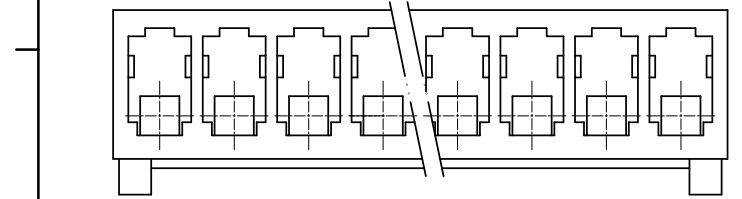

B	EC-23050134	CHANGE DRAWING	Perlman	2023.05.29
A		NEW RELEASE	Li Song	2017.01.11
REV.	ECN NO	REVISION RECORD	DRAW	DATE

TOLERANCE X. X.XXX ±0.10 X.X ±0.40 X.XX ±0.30 Angular ±2°		PART NO. 2541H-XP-X-XX-XX-HF		朝貴電子股份有限公司 CKM ELECTRONICS CO., LTD.	
		DRAWING NO. C-254101XX-XX		DESCRIPTION 2.54mm PITCH CRIMP TERMINAL SOCKET	
DWG TYPE. Customer Drawing		APPROVED BY Angus Chen 2023.05.29	CHECKED BY Lance 2023.05.29	DRAWN BY Perlman 2023.05.29	PAGE 1 OF 2 SCALE 4 : 1
				REV. B	

1 PROPOSAL

2 RoHS

3 HF

4 CKM
2023.06.01
研发部

5 6 CUST INFORMATION.

PART NO. DRAWING NO. REV.

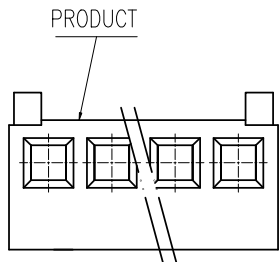

PE BAG

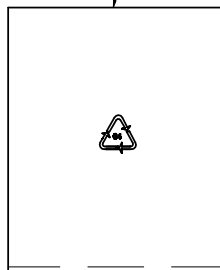

CARTON

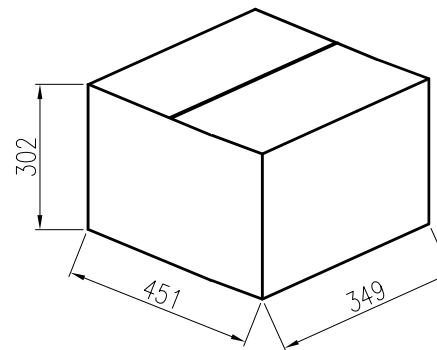
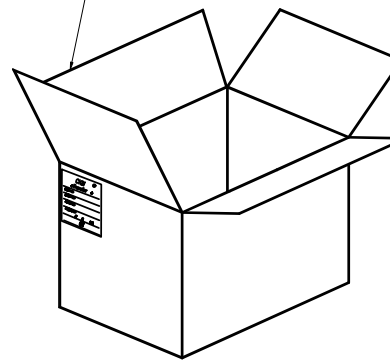

POS	PCS/PE BAG	PCS/CARTON	GROSS WEIGHT(KG)	NET WEIGHT(KG)
2	600	14400	3.81	3.31
3	600	14400	5.47	4.97
4	600	14400	6.98	6.48
5	600	14400	8.51	8.01
6	500	8000	5.87	5.37
7	500	8000	6.79	6.29
8	500	8000	7.72	7.22
9	500	8000	8.64	8.14
10	500	8000	9.56	9.06
11	500	8000	10.48	9.98
12	300	4800	7.04	6.54
13	300	4800	7.59	7.09
14	300	4800	8.15	7.65
15	300	4800	8.70	8.20
16	300	4800	8.26	8.76
17	250	3000	6.32	5.82
18	250	3000	6.67	6.17
19	250	3000	7.01	6.51
20	250	3000	7.36	6.86

TOLERANCE		PART NO.		朝貴電子股份有限公司	
X. X.X ±0.40	X.XXX ±0.10	2541H-XP-X-XX-XX-HF		CKM ELECTRONICS CO., LTD.	
X.XX ±0.30	Angular ±2°	DRAWING NO.		DESCRIPTION	
		C-254101XX-XX		2.54mm PITCH CRIMP TERMINAL SOCKET	
UNIT:	mm	APPROVED BY	CHECKED BY	DRAWN BY	PAGE
		Angus Chen	Lance	Perlman	20F2
DWG TYPE.	Customer Drawing	2023.05.29	2023.05.29	2023.05.29	SCALE
					4 : 1
					REV.
					B

B	EC-23050134	CHANGE DRAWING	Perlman	2023.05.18
A		NEW RELEASE	Li Song	2017.01.11
REV.	ECN NO	REVISION RECORD	DRAW	DATE