

# RoHS

## CUST INFORMATION.

PART NO.	DRAWING NO.	REV.
----------	-------------	------

A  
B  
C  
D

A  
B  
C  
D

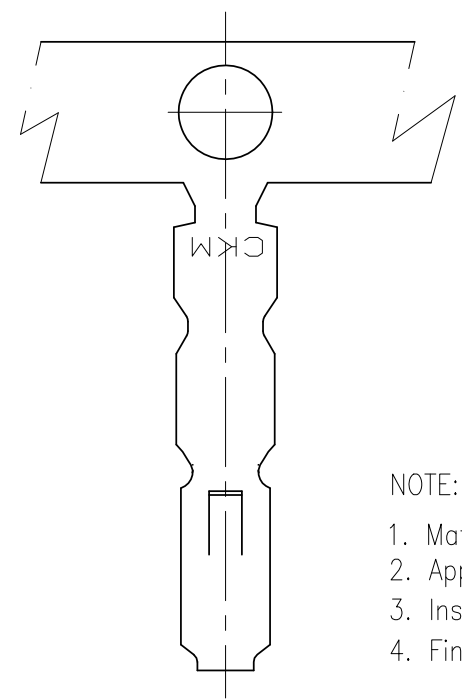
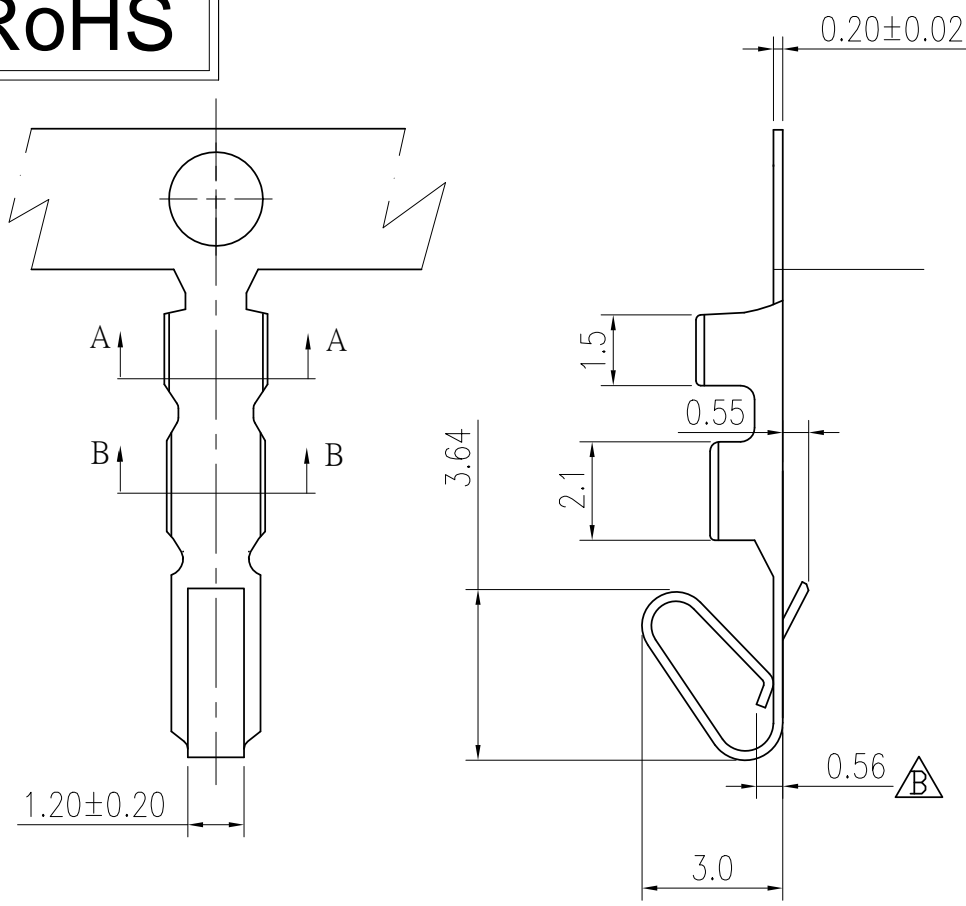

NOTE:

- Material: [A] : Brass, [B] :Phosphor bronze
- Applicable wires: AWG#28~#22
- Insulation O.D.: 1.2~1.7mm
- Finish: [1] 50u" Tin plated overall  
[2] 50u" Tin plated on crimping area, 1u" Au plated on contact area
- Q'ty / reel:10Kpcs
- Bill of Part No:

NO	PART NO	Material	Plated	LOGO	Finish
1	25410301	[B]	Pre-plating	CKM	[1]
2	25410303	[A]	Pre-plating	CKM	[1]
3	25410305	[A]	Pre-plating		[1]
4	25410306	[A]	Post plating	CKM	[2]
5	25410307	[B]	Post plating	CKM	[2]
6	25410308	[B]	Post plating	CKM	[1]

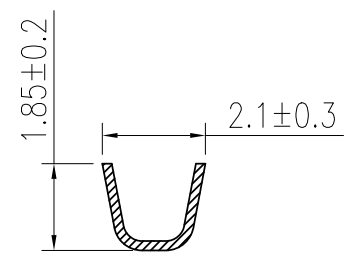

SEC A-A

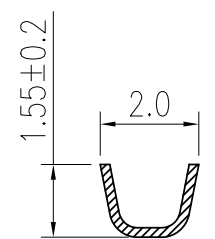

SEC B-B

<b>TOLERANCE</b>		<b>PART NO.</b>		朝貴電子股份有限公司 <b>CKM ELECTRONICS CO., LTD.</b>	
X. ±0.50	X.XXX ±0.15	2541030X			
X.X ±0.35		<b>DRAWING NO.</b>		<b>TITLE.</b>	
X.XX ±0.25	Angular ±5°	C-2541030X		MX2.54-T	
<b>UNIT:</b> mm		<b>APPROVED BY</b>	<b>CHECKED BY</b>	<b>DRAWN BY</b>	<b>PAGE</b>
		Jeff.wen	Sun.Lee	Angel.tong	10F2
<b>DWG TYPE.</b>		<b>APPROVED BY</b>	<b>CHECKED BY</b>	<b>DRAWN BY</b>	<b>SCALE</b>
Customer Drawing		2021.05.11	2021.05.11	2021.05.11	4 : 1
					<b>REV.</b>
					C

C	EC-21050887	INCREASE PACKING	Angel.tong	2021.05.11
B		CHANGE DIMENSION		2010.10.08
<b>REV.</b>	<b>ECN NO</b>	<b>REVISION RECORD</b>	<b>DRAW</b>	<b>DATE</b>

# RoHS

CUST INFORMATION.

PART NO.	DRAWING NO.	REV.
----------	-------------	------

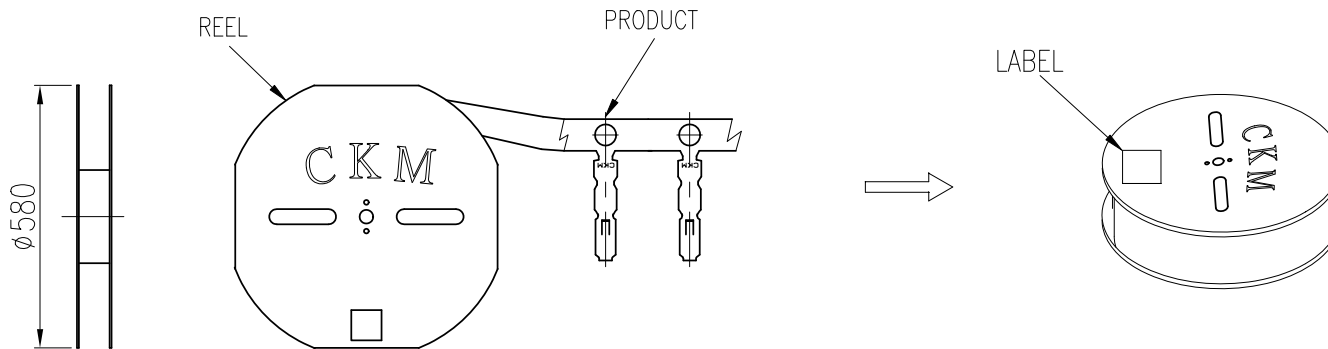

PCS/REEL	PCS/CARTON	GROSS WEIGHT(KG)	NET WEIGHT(KG)
10000	100000	8.70	9.49

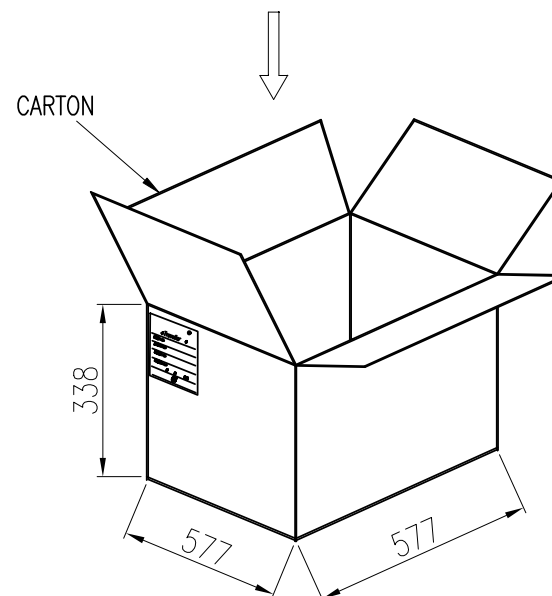
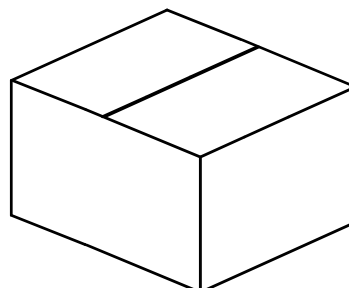

<b>TOLERANCE</b> X. ±0.50    X.XXX ±0.15 X.X ±0.35 X.XX ±0.25    Angular ±5°		<b>PART NO.</b> 2541030X		朝貴電子股份有限公司 CKM ELECTRONICS CO., LTD.	
		<b>DRAWING NO.</b> C-2541030X		<b>TITLE.</b> MX2.54-T	
<b>UNIT:</b> mm		<b>APPROVED BY</b> Jeff.wen 2021.05.11	<b>CHECKED BY</b> Sun.Lee 2021.05.11	<b>DRAWN BY</b> Angel.tong 2021.05.11	<b>PAGE</b> 20F2  <b>SCALE</b> 4 : 1
<b>DWG TYPE.</b> Customer Drawing				<b>REV.</b> C	

C	EC-21050887	INCREASE PACKING	Angel.tong	2021.05.11
B		CHANGE DIMENSION		2010.10.08
REV.	ECN NO	REVISION RECORD	DRAW	DATE