

RoHS



CUST INFORMATION.

PART NO.	DRAWING NO.	REV.
----------	-------------	------

NOTE:

1.MATERIAL: NYLON 66 UL94V-0

2.BILL OF PART NO.

2514H-XP-X-HF

NO. OF CIRCUITS:2~20

COLOR: BLANK(NATURAL)

C: RED

L: BLACK

3.RoHS & HF COMPLIANCE

4.FOR COLOR,AVAILABILITY,DELIVERY & MOQ,

CONTACT CKM

5.DIMENSIONAL

6.PACKAGE:PE BAG

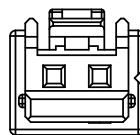
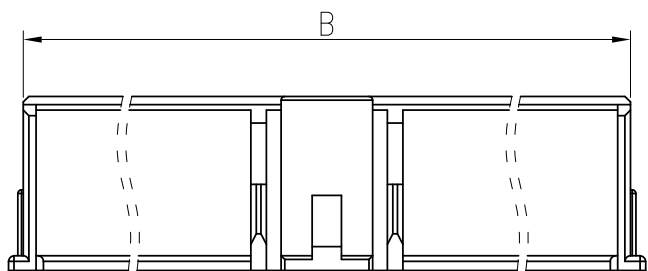

2P

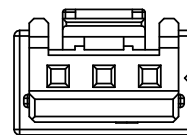

3P

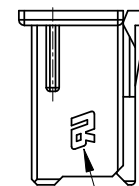
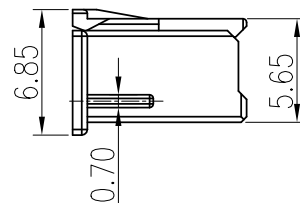
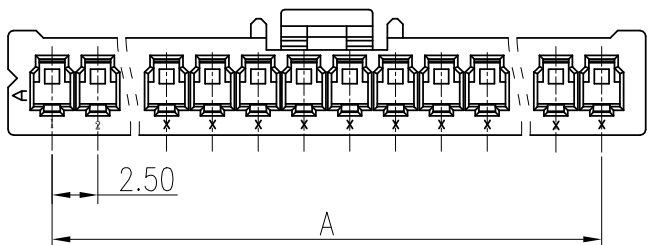

ONLY 2P

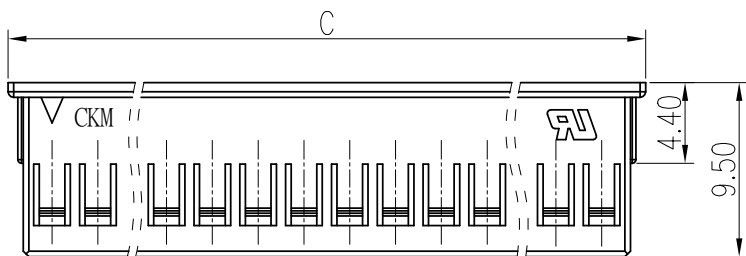

OLD P/N	NEW P/N	COLOR
25140101-XXHF	2514H-XP-HF	NATURAL
25140102-XXHF	2514H-XP-C-HF	RED
25140103-XXHF	2514H-XP-L-HF	BLACK

POS	A	B	C
2	2.5	5.64	7.3
3	5.0	8.14	9.8
4	7.5	10.64	12.3
5	10.0	13.14	14.8
6	12.5	15.64	17.3
7	15.0	18.14	19.8
8	17.5	20.64	22.3
9	20.0	23.14	24.8
10	22.5	25.64	27.3
11	25.0	28.14	29.8
12	27.5	30.64	32.3
13	30.0	33.14	34.8
14	32.5	35.64	37.3
15	35.0	38.14	39.8
16	37.5	40.64	42.3
17	40.0	43.14	44.8
18	42.5	45.64	47.3
19	45.0	48.14	49.8
20	47.5	50.64	52.3



TOLERANCE		PART NO.	朝貴電子股份有限公司 CKM ELECTRONICS CO., LTD.	
X.	X.XXX ±0.10	2514H-XP-X-HF	TITLE: 2.5mm PITCH HOUSING	
X.X	±0.30	DRAWING NO.	C-2514010X-XXHF	
X.XX	±0.20	CHECKED BY	Angus Chen 2023.07.05	Sun.lee 2023.07.05
UNIT: mm		DRAWN BY	Angel.tong 2023.07.05	PAGE 10F2
DWG TYPE. Customer Drawing		APPROVED BY	SCALE 2:1	REV. E

E	EC-23071607	ADD P/N LIST	Angel.tong	2023.07.05
D		ADD PACKAGE	Li Song	2016.12.26
REV.	ECN NO	REVISION RECORD	DRAW	DATE

RoHS



PE BAG

CUST INFORMATION.

PART NO.	DRAWING NO.	REV.
----------	-------------	------

A

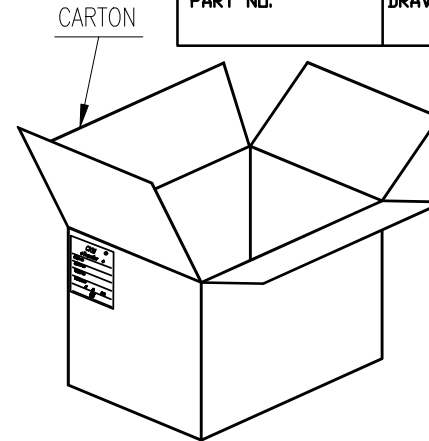
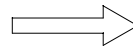
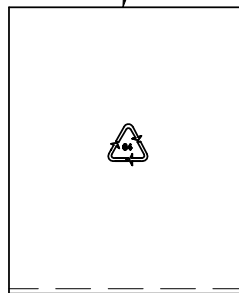
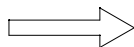
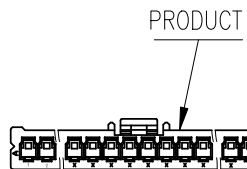

A

B

POS	PCS/PE BAG	PCS/CARTON	GROSS WEIGHT(KG)	NET WEIGHT(KG)
2	600	14400	3.09	2.59
3	600	14400	4.60	4.10
4	600	14400	5.51	5.01
5	600	14400	6.48	5.98
6	500	8000	4.26	3.76
7	500	8000	4.78	4.28
8	500	8000	5.30	4.80
9	500	8000	5.78	5.28
10	500	8000	6.26	5.76
11	500	8000	6.66	6.16
12	300	4800	4.53	4.03
13	300	4800	4.87	4.37
14	300	4800	5.06	4.56
15	300	4800	5.40	4.90
16	300	4800	5.73	5.23
17	250	3000	4.01	3.51
18	250	3000	4.22	3.72
19	250	3000	4.40	3.90
20	250	3000	4.61	4.11

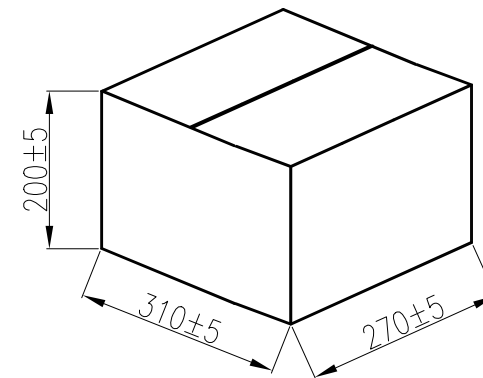

B

C

C

D

D

TOLERANCE X. X.XXX ±0.10 X.X ±0.30 X.XX ±0.20 Angular ±2°		PART NO. 2514H-XP-X-HF		朝貴電子股份有限公司 CKM ELECTRONICS CO., LTD.	
UNIT: mm DWG TYPE. Customer Drawing		DRAWING NO. C-2514010X-XXHF		TITLE: 2.5mm PITCH HOUSING	
APPROVED BY	CHECKED BY	DRAWN BY	PAGE	REV.	
Angus Chen 2023.07.05	Sun.lee 2023.07.05	Angel.tong 2023.07.05	20F2	E	
			SCALE		
			2 : 1		

E	EC-23071607	ADD P/N LIST	Angel.tong	2023.07.05
D		ADD PACKAGE	Li Song	2016.12.26
REV.	ECN NO	REVISION RECORD	DRAW	DATE

1

2

3

4

5

6 QMI-P12-05-01