

RoHS



CUST INFORMATION.

PART NO.	DRAWING NO.	REV.
----------	-------------	------

A  
B  
C  
D

A  
B  
C  
D

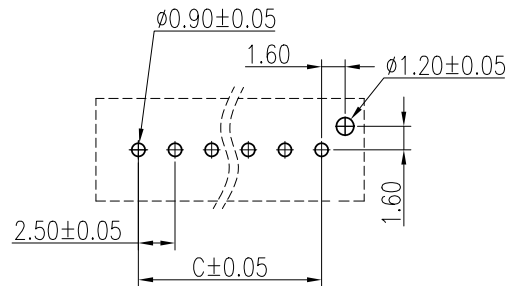
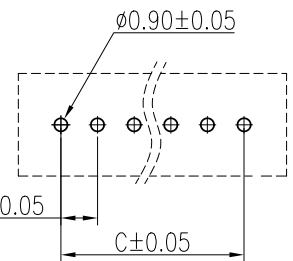
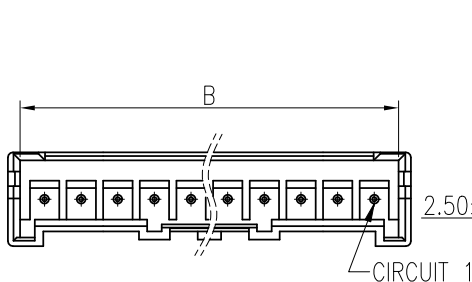

RECOMMENDED PCB LAYOUT  
PCB THK=1.6±0.05  
FOR W/O BOSS

RECOMMENDED PCB LAYOUT  
PCB THK=1.6±0.05  
FOR W/ BOSS

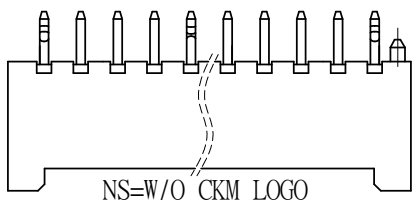
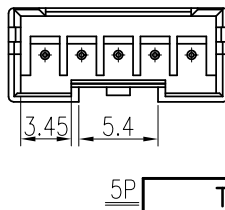
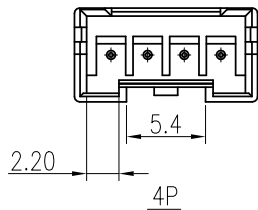
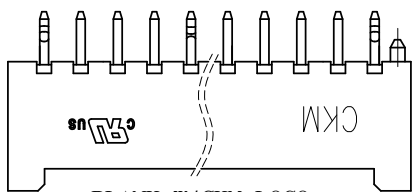
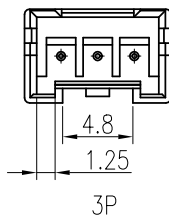
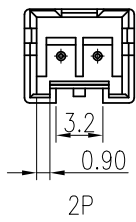
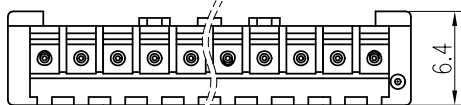
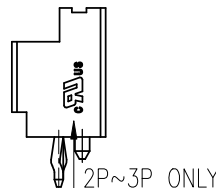
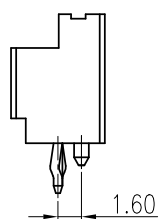
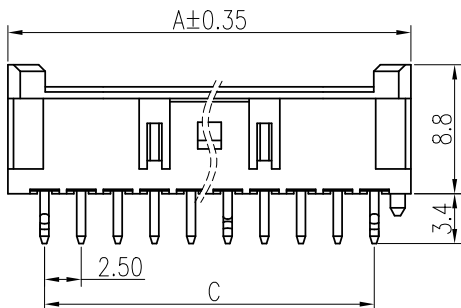

47.50	50.83	52.50	20
45.00	48.33	50.00	19
42.50	45.83	47.50	18
40.00	43.33	45.00	17
37.50	40.83	42.50	16
35.00	38.33	40.00	15
32.50	35.83	37.50	14
30.00	33.33	35.00	13
27.50	30.83	32.50	12
25.00	28.33	30.00	11
22.50	25.83	27.50	10
20.00	23.33	25.00	9
17.50	20.83	22.50	8
15.00	18.33	20.00	7
12.50	15.83	17.50	6
10.00	13.33	15.00	5
7.50	10.83	12.50	4
5.00	8.33	10.00	3
2.50	5.83	7.50	2
DIM C	DIM B	DIM A	POS

NOTE:

- MATERIAL SPECIFICATION:
  - INSULATION: NYLON 66 UL 94V-0, NATURAL
  - CONTACT:  $\phi 0.60$ mm BRASS BRONZE
- FINISH:
  - SOLDERING AREA: SEE PART NO;
  - UNDER PLATING: NICKEL PLATING 50  $\mu$ " THICKNESS MIN. OVERALL.
- BILL OF PART NO:
 

2514WV-XP-XX-XX-XXX-XX-HF

  - NO. OF CIRCUITS: 2~20
  - CONTACT FINISH
    - A: MATTE TIN PLATING (OVERALL)
    - B: BRIGHT TIN PLATING (OVERALL)
    - C: GOLD FLASH (OVERALL)
  - COLOR: BLANK(NATURAL) OR A~Z
- FOR COLOR, AVAILABILITY, DELIVERY & MOQ, CONTACT CKM
- DIMENSIONAL
- PACKAGE: PE BAG

COLOR CODE	
BLANK	NATURAL
A	BLACK
C	RED
E	YELLOW
G	BLUE

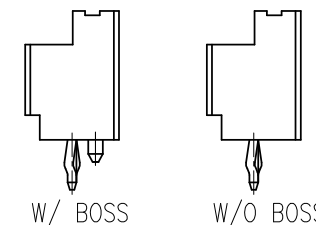
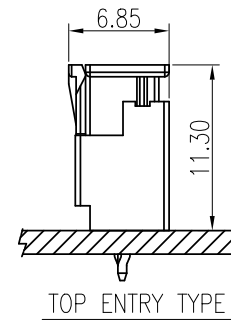

<b>TOLERANCE</b> X. X.XXX ±0.10 X.X ±0.30 X.XX ±0.20 Angular ±2°		<b>PART NO.</b> 2514WV-XP-XX-XX-XXX-XX-HF		朝貴電子股份有限公司 CKM ELECTRONICS CO., LTD.	
		<b>DRAWING NO.</b> C-2514020X-XXHF		<b>TITLE.</b> 2.5mm PITCH VERTICAL DIP TYPE HEADER	
<b>DWG TYPE.</b> Customer Drawing		<b>APPROVED BY</b> Angus 2023.06.30	<b>CHECKED BY</b> Lance Cheng 2023.06.30	<b>DRAWN BY</b> Shawn 2023.06.30	<b>PAGE</b> 10F2  <b>SCALE</b> 2 : 1
				<b>REV.</b> D	

D	EC-23060142	ADD KINK DRAWING	Shawn	2023.06.30
C		ADD PACKAGE	Li Song	2017.01.11
REV.	ECN NO	REVISION RECORD	DRAW	DATE

RoHS



CUST INFORMATION.

PART NO.	DRAWING NO.	REV.
----------	-------------	------

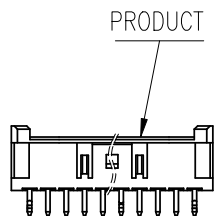

PRODUCT

PE BAG

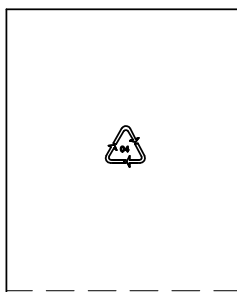

CARTON

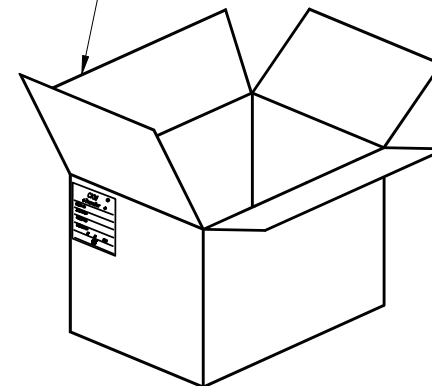

POS	PCS/PE BAG	PCS/CARTON
2	600	14400
3	600	14400
4	600	14400
5	600	14400
6	500	8000
7	500	8000
8	500	8000
9	500	8000
10	500	8000
11	500	8000
12	300	4800
13	300	4800
14	300	4800
15	300	4800
16	300	4800
17	250	3000
18	250	3000
19	250	3000
20	250	3000

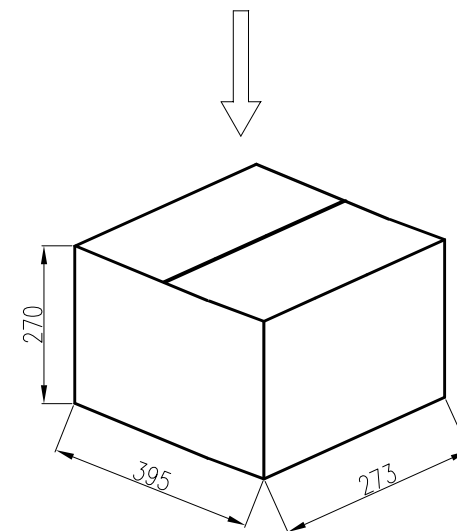
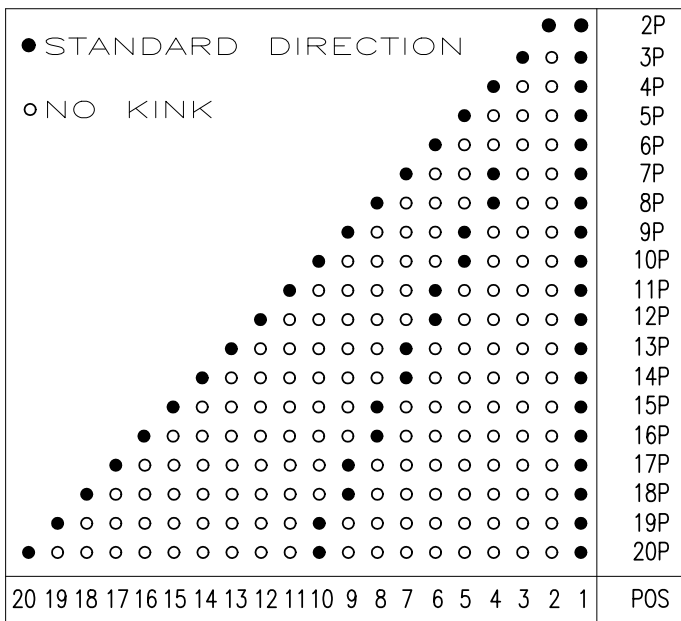
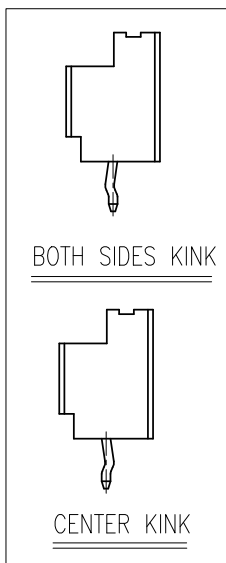

D	EC-23060142	ADD KINK DRAWING	Shawn	2023.06.30
C		ADD PACKAGE	Li Song	2017.01.11
REV.	ECN NO	REVISION RECORD	DRAW	DATE

<b>TOLERANCE</b> X. X.XXX ±0.10 X.X ±0.30 X.XX ±0.20 Angular ±2°		<b>PART NO.</b> 2514WV-XP-XX-XX-XXX-XX-HF		朝貴電子股份有限公司 CKM ELECTRONICS CO., LTD.	
<b>UNIT:</b> mm		<b>DRAWING NO.</b> C-2514020X-XXHF		<b>TITLE:</b> 2.5mm PITCH VERTICAL DIP TYPE HEADER	
<b>DWG TYPE.</b> Customer Drawing		<b>APPROVED BY</b> Angus 2023.06.30	<b>CHECKED BY</b> Lance Cheng 2023.06.30	<b>DRAWN BY</b> Shawn 2023.06.30	<b>PAGE</b> 20F2 <b>SCALE</b> 2 : 1
				<b>REV.</b> D	

1 2 3 4 5 6

A

B

C

D

A

B

C

D