

RoHS

CUST INFORMATION.

PART NO.	DRAWING NO.	REV.
----------	-------------	------

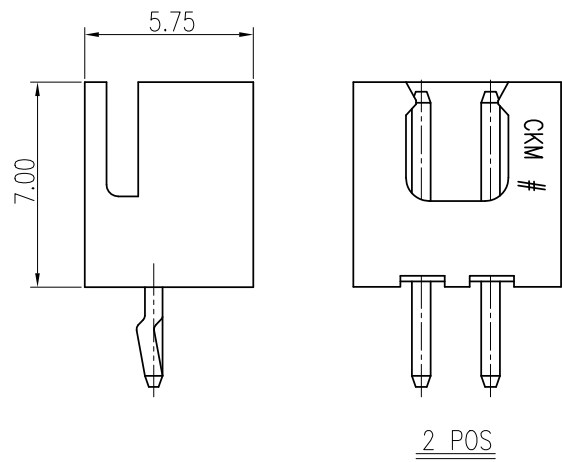
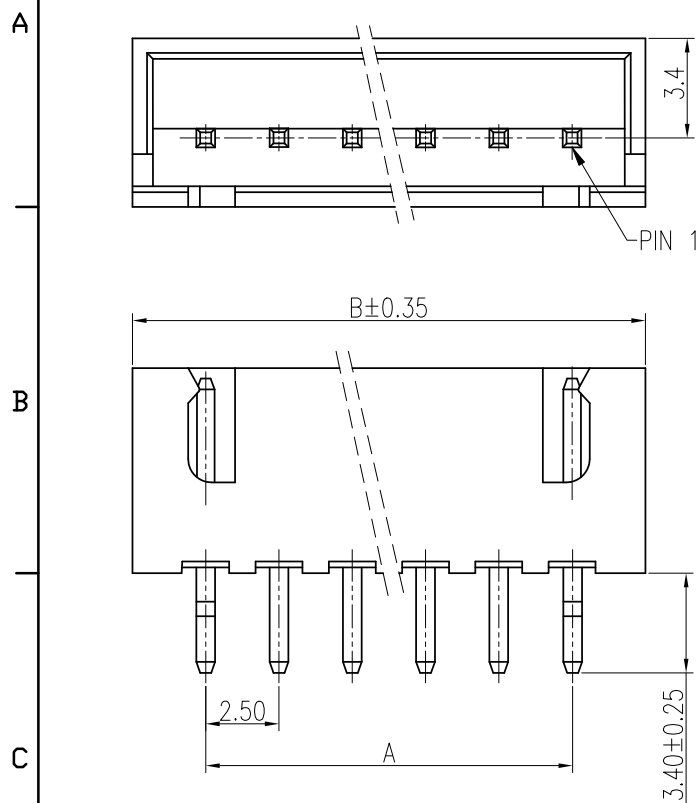

NOTE:

- 1. MATERIAL:
 - 1.1 INSULATOR: NYLON 66 UL 94V-0
 - 1.2 CONTACT: SQ 0.64mm BRASS, TIN PLATED
- 2. RoHS & HALOGEN-FREE COMPLIANCE
- 3. BILL OF PART NO:
 - 2501WV-XP-BX-XXX-HF
 - VOID CIRCUITS: BLANK=STANDARD OR 1~3 ALPHANUMERIC DIGITS
 - COLOR: K=WHITE(NATURAL) OR A~G
- 4. FOR COLOR, AVAILABILITY, DELIVERY & MOQ, CONTACT CKM
- 5. DIMENSIONAL

NO. OF CIRCUITS: 2~16

POS	A	B	POS	A	B
2	2.50	7.5	10	25.50	27.5
3	5.00	10.0	11	25.00	30.0
4	7.50	12.5	12	27.50	32.5
5	10.00	15.0	13	30.00	35.0
6	12.50	17.5	14	32.50	37.5
7	15.00	20.0	15	35.00	40.0
8	17.50	25.5	16	37.50	42.5
9	20.00	25.0			

COLOR CODE	
A	BLACK
C	RED
F	GREEN
G	BLUE
K	WHITE

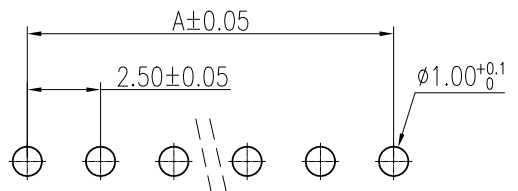

RECOMMENDED PCB LAYOUT
PCB THK=1.6mm

TOLERANCE		PART NO.		朝貴電子股份有限公司 CKM ELECTRONICS CO., LTD.	
X.	X.XXX ±0.10	2501WV-XP-XX-XXX-HF			
X.X	±0.30	DRAWING NO.		TITLE.	
X.XX	±0.20	C-250102XX-XXHF		2.50mm PITCH VERTICAL DIP TYPE CONNECTOR	
UNIT: mm	APPROVED BY	CHECKED BY	DRAWN BY	PAGE	REV.
	Ivan Su	李德亮	周桂林	1 OF 2	E
DWG TYPE.	2022. 02. 17	2022. 02. 17	2022. 02. 17	SCALE	
Customer Drawing				4 : 1	

E	EC-23021450	移除UL&CSA Logo	周桂林	2022.02.17
D	EC-22021127	ADJUST FINISH & COLOR OPTIONS	Jimmy Wang	2022.02.10
REV.	ECN NO	REVISION RECORD	DRAW	DATE

RoHS

CUST INFORMATION.

PART NO.	DRAWING NO.	REV.
----------	-------------	------

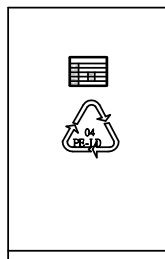
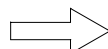

BAG

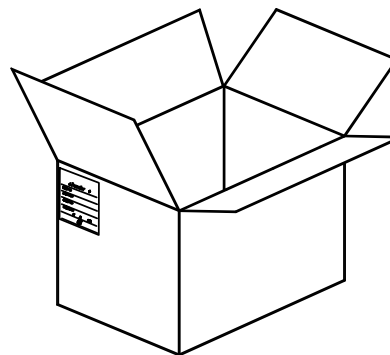
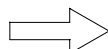

CARTON

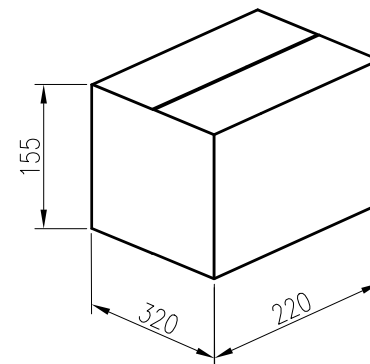
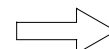

POS	PCS/BAG	PCS/CARTON	NET WEIGHT	GROSS WEIGHT
2	1000	15000	3.51	4.11
3		14000	4.42	5.02
4		12000	4.70	5.30
5		10000	4.75	5.35
6		8000	5.17	5.77
7		7000	5.25	5.85
8	500	5000	4.83	5.43
9		5000	5.41	6.01
10		4000	4.95	5.55
11		4000	5.16	5.76
12	250	3500	4.86	5.46
13		3250	4.80	5.40
14		3000	4.91	5.51
15		3000	4.66	5.26
16	2500	4.32	4.92	



TOLERANCE X. X.XXX ±0.10 X.X ±0.30 X.XX ±0.20 Angular ±2°		PART NO. 2501WV-XP-XX-XXX-HF		朝貴電子股份有限公司 CKM ELECTRONICS CO., LTD.	
UNIT: mm		DRAWING NO. C-250102XX-XXHF		TITLE. 2.50mm PITCH VERTICAL DIP TYPE CONNECTOR	
DWG TYPE. Customer Drawing		APPROVED BY Ivan Su 2022. 02. 17	CHECKED BY 李德亮 2022. 02. 17	DRAWN BY 周桂林 2022. 02. 17	PAGE 2 OF 2 SCALE 4 : 1
				REV. E	

E	EC-23021450	移除UL&CSA Logo	周桂林	2022.02.17
D	EC-22021127	ADJUST FINISH & COLOR OPTIONS	Jimmy Wang	2022.02.10
REV.	ECN NO	REVISION RECORD	DRAW	DATE