

Proposal Drawing

CUST INFORMATION.

NOTE

1. MATERIAL: NYLON 66 UL 94V-0
2. RoHS & HF COMPLIANCE
3. BILL OF PART NO:

PART NO. NA	DRAWING NO. NA	REV. NA
----------------	-------------------	------------

2021H-XP-X-HF
 POS:10~40P
 HF=HALOGEN FREE
 COLOR: BLANK(NATURAL)

4. FOR COLOR, AVAILABILITY, DELIVERY & MOQ, CONTACT CKM
5. MATES WITH

PLUG ST HEADER	2021WV SERIES
PLUG R/A HEADER	2021WR SERIES

6. APPLICABLE TERMINAL

REC. CRIMP TERMINAL (AWG #22-26) (TIN PLATING)	2021TOP-BX SERIES
REC. CRIMP TERMINAL (AWG #26-28) (TIN PLATING)	2021T1P-BX SERIES

7. DIMENSIONAL

40.6	38	42	40
38.6	36	40	38
36.6	34	38	36
34.6	32	36	34
32.6	30	34	32
30.6	28	32	30
28.6	26	30	28
26.6	24	28	26
24.6	22	26	24
22.6	20	24	22
20.6	18	22	20
18.6	16	20	18
16.6	14	18	16
14.6	12	16	14
12.6	10	14	12
10.6	8	12	10
C	B	A	POS

A

B

C

D

A

B

C

D

10P SPECS

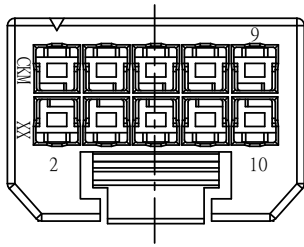

12~40P SPECS

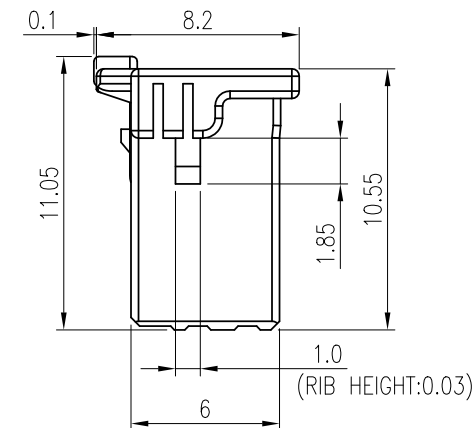
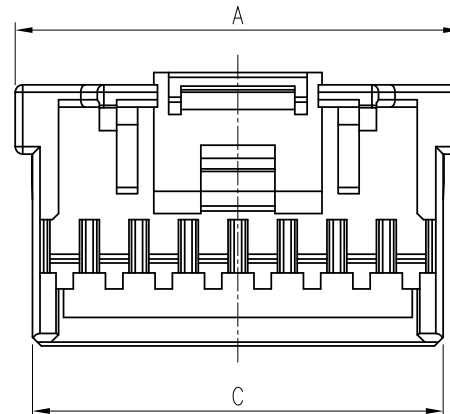
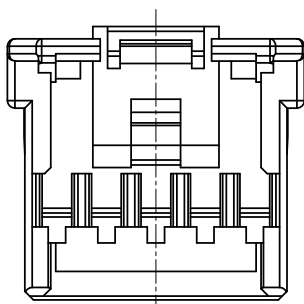
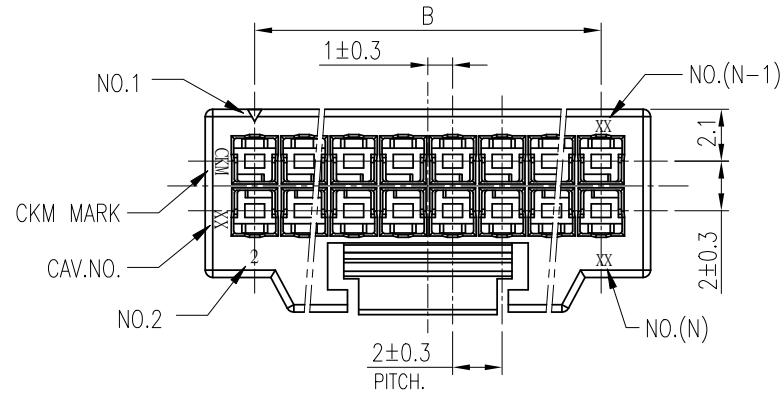

CKM
2023.08.22
研发部

TOLERANCE X. ±0.50 X.XXX ±0.15 X.X ±0.35 X.XX ±0.25 Angular ±5°		PART NO. 2021H-XP-X-HF		朝貴電子股份有限公司 CKM ELECTRONICS CO., LTD.	
		DRAWING NO. C-2021H-XP-X-HF		TITLE. IGRID 2.0MM W/B DUAL RCPT HSG	
DWG TYPE. Customer Drawing		APPROVED BY Ivan_Su 2022/07/14	CHECKED BY Deliang Li 2022/07/14	DRAWN BY Ryan 2022/07/14	PAGE 1 OF 1 SCALE 4 : 1
				REV. A1	

A1		RENEW THE DRAWING	Ryan	2022/07/14
A		NEW RELEASE	HEIMER	2020/11/25
REV.	ECN NO	REVISION RECORD	DRAW	DATE