

RoHS

HF

CUST INFORMATION.

PART NO.	DRAWING NO.	REV.
----------	-------------	------

5. DIMENSIONAL

POS	A	B	C	D
40	42	38	40.7	9.2
38	40	36	38.7	9.2
36	38	34	36.7	9.2
34	36	32	34.7	9.2
32	34	30	32.7	9.2
30	32	28	30.7	9.2
28	30	26	28.7	9.2
26	28	24	26.7	9.2
24	26	22	24.7	9.2
22	24	20	22.7	9.2
20	22	18	20.7	9.2
18	20	16	18.7	9.2
16	18	14	16.7	9.2
14	16	12	14.7	9.2
12	14	10	12.7	9.2
10	12	8	10.7	7.3

NOTE:

- 1. MATERIAL:
    - 1.1. INSULATOR:LCP UL 94V-0
    - 1.2. CONTACT=SQ 0.50mm BRASS
  - 2. FINISH: TIN
  - 3. RoHS & HF COMPLIANCE
  - 4. BILL OF PART NO:
    - 2021WV-XP-XX-XX-HF
- No OF CIRCUITS: 10~40
- PIN TAIL(DIM E)  
BLANK: 3.20  
2.2 : 2.20mm
- COLOR: BLANK(NATURAL) OR A=BLACK  
FINISH: A=MATTE-TIN PLATING  
B=BRIGHT-TIN PLATING

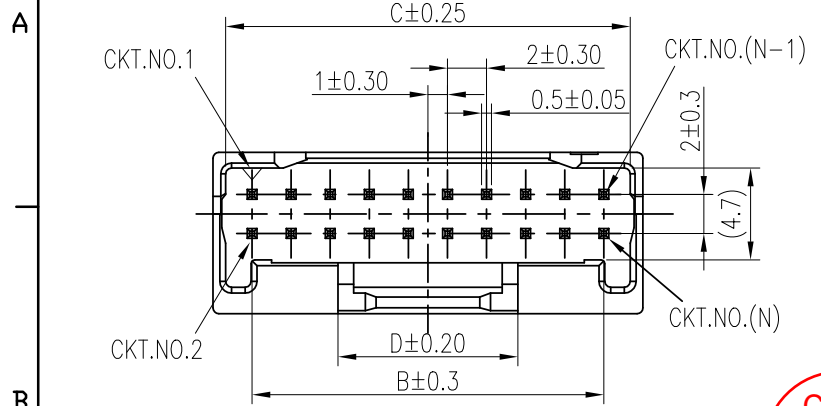

CKM  
2023.08.22  
研发部

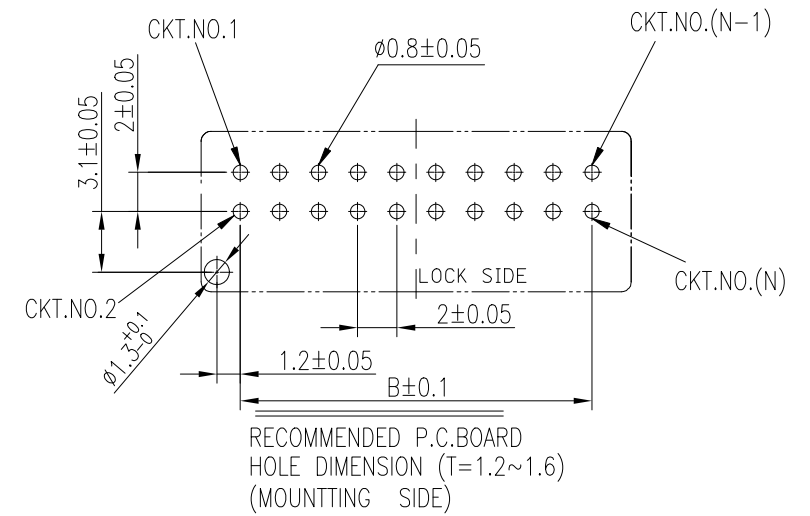
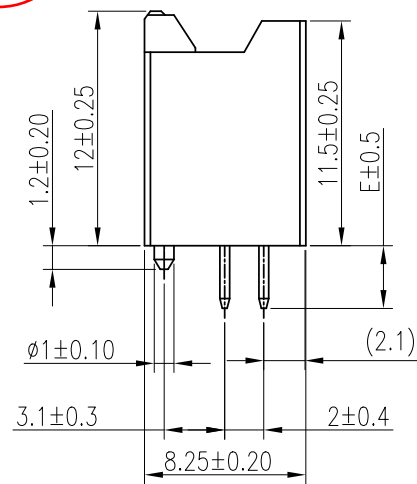
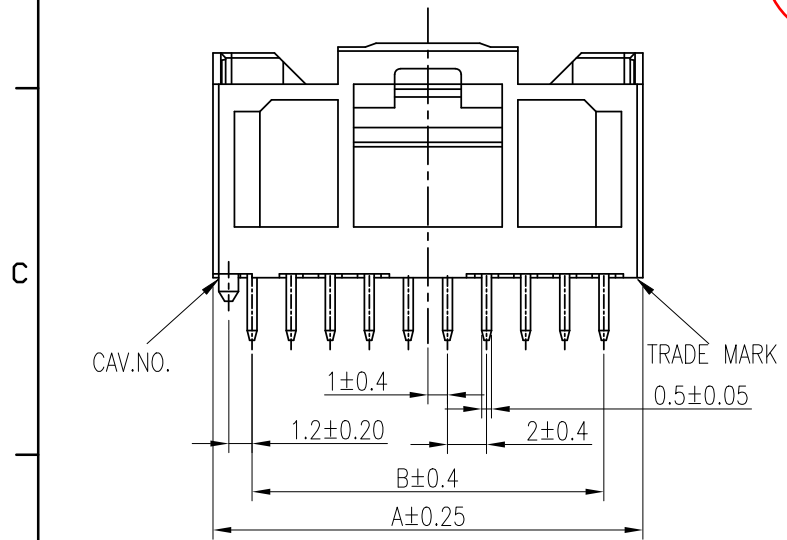

<b>TOLERANCE</b> X. ±0.50 X.XXX ±0.15 X.X ±0.35 X.XX ±0.25 Angular ±5°		<b>PART NO.</b> 2021WV-XP-XX-XX-HF		朝貴電子股份有限公司 CKM ELECTRONICS CO., LTD.	
		<b>DRAWING NO.</b> C-2021WV-XP-XX-XX-HF		<b>TITLE.</b> IGRID 2.0MM W/B DUAL DIP PLUG ASSY ST(WITH BOSS)	
<b>DWG TYPE.</b> Customer Drawing		<b>APPROVED BY</b> Ivan Su 2022/07/11	<b>CHECKED BY</b> Deliang Li 2022/07/11	<b>DRAWN BY</b> Ryan 2022/07/11	<b>PAGE</b> 1 OF 2  <b>SCALE</b> 4 : 1
				<b>REV.</b> A1	

A1		RENEW THE DRAWING	Ryan	2022/07/11
A		NEW RELEASE	HEIMER	2021/01/08
REV.	ECN NO	REVISION RECORD	DRAW	DATE

RoHS

HF

6. PACKAGE DRAWING

CUST INFORMATION.

PART NO.	DRAWING NO.	REV.
----------	-------------	------

A

B

A

B

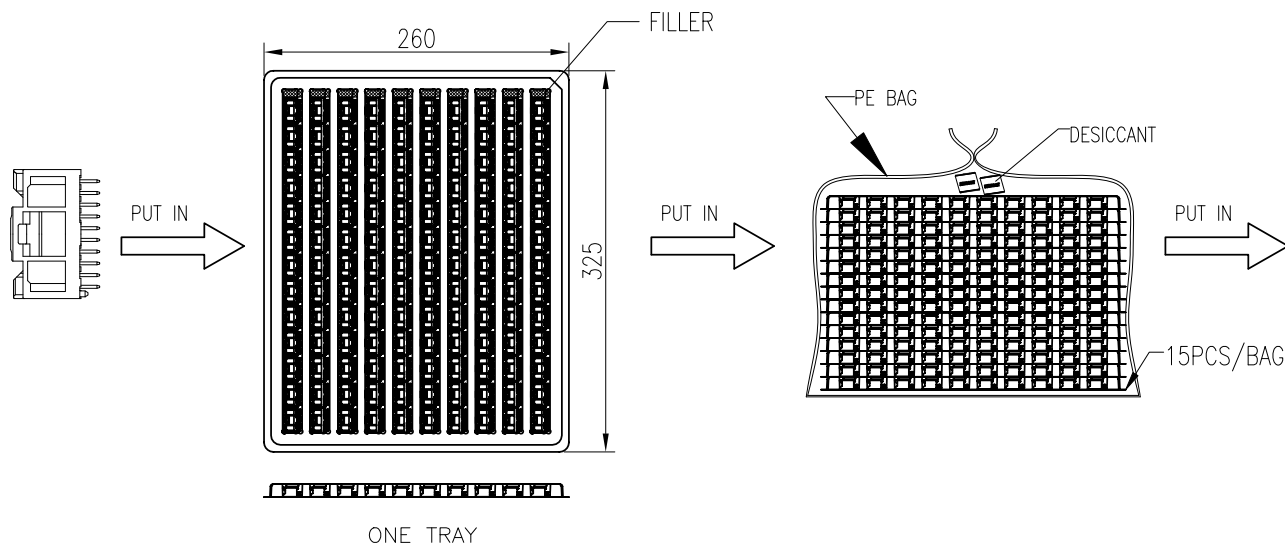

7. STANDARD PACKAGING QUANTITY

CKT. SIZE	PLASTIC TRAY (15 ROWS)		SHIPPING CARTON	
	QTY. IN ONE TRAY(pcs)	TRAYS NUMBER OF TRAYS	QUANTITY(pcs)	
10	240	15	3600	
12	200	15	3000	
14	180	15	2700	
16	160	15	2400	
18	140	15	2100	
20	130	15	1950	
22	120	15	1800	
24	110	15	1650	
26	100	15	1500	
28	90	15	1350	
30	90	15	1350	
32	80	15	1200	
34	80	15	1200	
36	70	15	1050	
38	70	15	1050	
40	60	15	900	



C

C

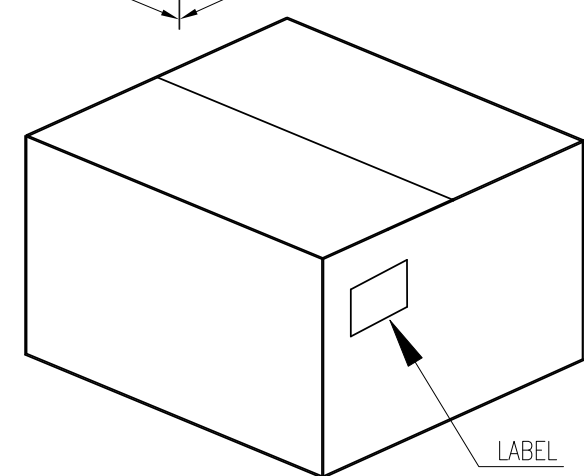

D

D

<b>TOLERANCE</b> X. ±0.50 X.XXX ±0.15 X.X ±0.35 X.XX ±0.25 Angular ±5°		<b>PART NO.</b> 2021WV-XP-XX-XX-HF		朝貴電子股份有限公司 CKM ELECTRONICS CO., LTD.	
<b>UNIT:</b> mm		<b>DRAWING NO.</b> C-2021WV-XP-XX-XX-HF		<b>TITLE:</b> IGRID 2.0MM W/B DUAL DIP PLUG ASSY ST(WITH BOSS)	
<b>DWG TYPE.</b> Customer Drawing		<b>APPROVED BY</b> Ivan Su 2022/07/11	<b>CHECKED BY</b> Deliang Li 2022/07/11	<b>DRAWN BY</b> Ryan 2022/07/11	<b>PAGE</b> 2 OF 2  <b>SCALE</b> 4 : 1
				<b>REV.</b> A1	

1

2

3

4

5

6 QMI-P12-05-01