

RoHS

HF

CUST INFORMATION.

PART NO.	DRAWING NO.	REV.
----------	-------------	------

NOTE:

1. MATERIAL:

- 1.1. INSULATION: NYLON 6T UL 94V-0
- 1.2. CONTACT=SQ 0.50mm BRASS
- 1.3 SOLDER TAB: THICK 0.40mm BRASS $\triangle E$

2. FINISH: TIN OR GOLD PLATING

3. RoHS & HF COMPLIANCE

4. BILL OF PART NO:

2015WRS-XP-XX-HF

POS:2~16 ← HF=HALOGEN FREE

FINISH: ← COLOR: BLANK(NATURAL) OR A=BLACK

A=MATTE-TIN PLATING

B=BRIGHT-TIN PLATING

C=GOLD FLASH PLATING

5. FOR FINISH, COLOR, AVAILABILITY, DELIVERY & MOQ, CONTACT CKM

6. DIMENSIONAL

POS	A	B	C	D
2	-	8.0	-	2.4
3	4.00	10.0	-	4.1
4	6.00	12.0	-	5
5	8.00	14.0	7.00	
6	10.00	16.0		
7	12.00	18.0		
8	14.00	20.0	13.60	11.5
9	16.00	22.0		
10	18.00	24.0		
11	20.00	26.0	13.60	11.5
12	22.00	28.0		
13	24.00	30.0		
14	26.00	32.0	13.60	11.5
15	28.00	34.0		
16	30.00	36.0		

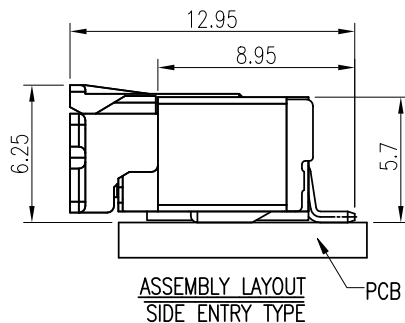
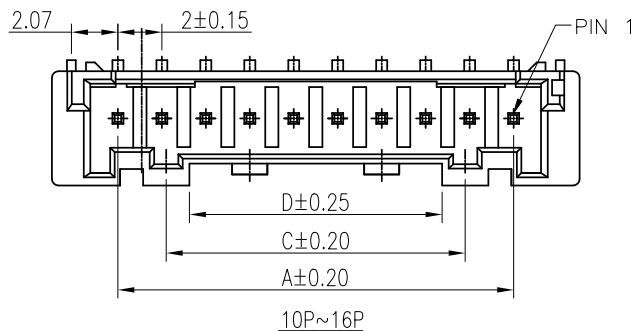

ASSEMBLY LAYOUT SIDE ENTRY TYPE

A

A

B

B

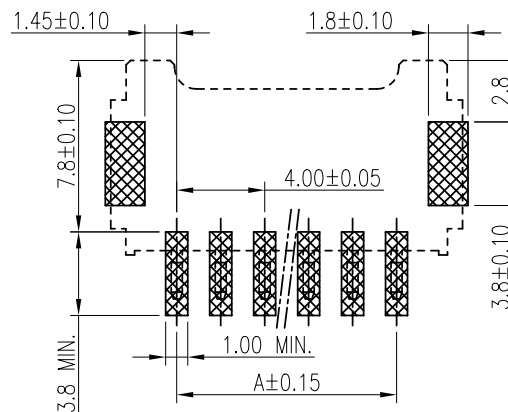
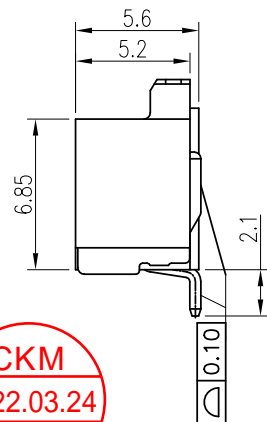
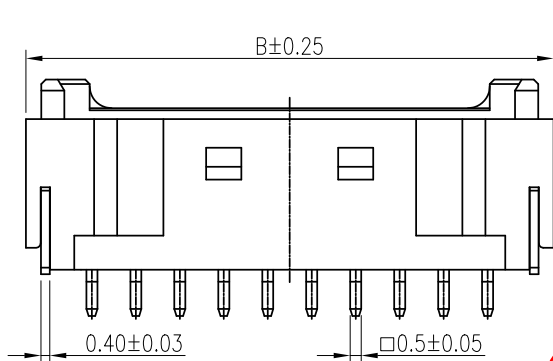

PCB LAYOUT PCB THICKNESS 1.6mm

C

C

2P 3P ADD CAP ONLY

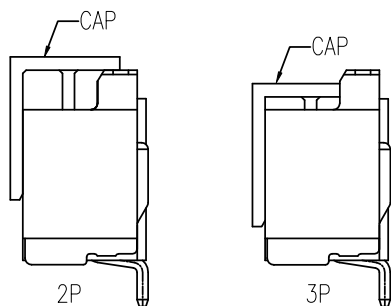

CKM 2022.03.24 研发部

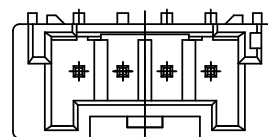
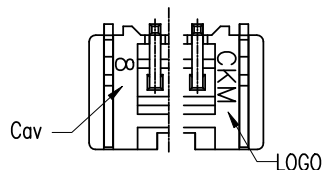

2P~4P

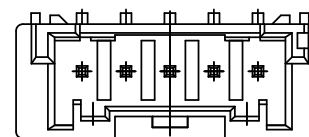

5P~9P

D

D

TOLERANCE		PART NO.		朝貴電子股份有限公司 CKM ELECTRONICS CO., LTD.
X. ±0.50	X.XXX ±0.15	2015WRS-XP-XX-HF		
X.X ±0.35		DRAWING NO.		TITLE: 2.0mm PITCH RIGHT ANGLE SMT TYPE CONNECTOR
X.XX ±0.25	Angular ±5°	C-2015WRS-XP-XX-HF		
	UNIT: mm	APPROVED BY	CHECKED BY	DRAWN BY
	DWG TYPE: Customer Drawing	Ivan_Su	Deliang Li	Ryan
		2022/03/21	2022/03/21	2022/03/21
				PAGE 1 OF 2
				SCALE 3 : 1
				REV. 1

I	EC-22031157	Update drawing	Ryan	2022/03/21
H	EC-21070941	Modify 14P15p16p, package quantity	Heimer	2021/06/30
REV.	ECN NO	REVISION RECORD	DRAW	DATE

RoHS

HF

CUST INFORMATION.

PART NO. DRAWING NO. REV.

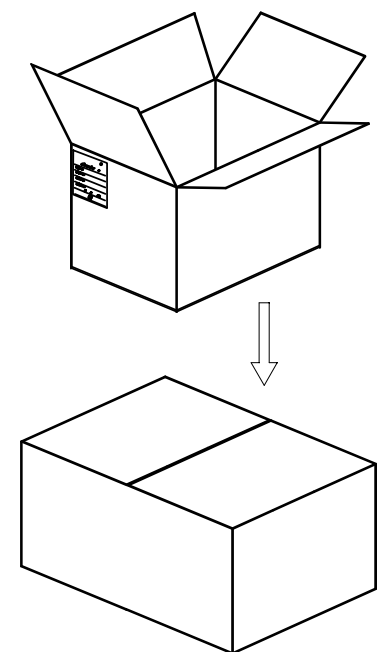
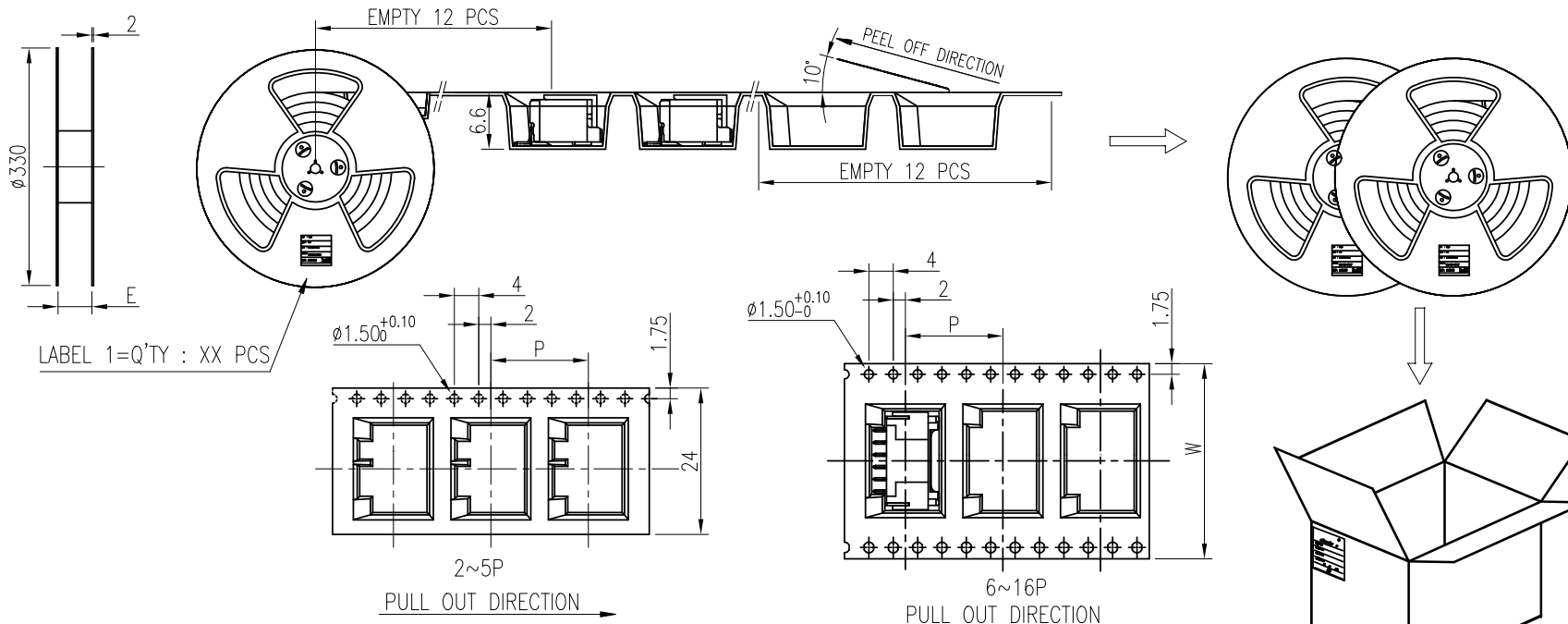

CKM
2022.03.24
研发部

POS	LABEL 1 Q TY	LABEL 2 Q TY	Weight Unit:(Kg) (G)		DIMENSIONS		
	PCS / REEL	PCS / CARTON	Net Weight	Gross Weight	W	E	P
2	400	2000	1.06	3.27			20
3	(G) 500	2500	1.49	4.08	24	25.5	16
4	500	2500	1.41	4.00			
5	500	2500	1.57	4.16			
6	500	2500	1.74	4.33			
7	500	2500	1.90	4.49	32	33.5	
8	500	2500	2.07	4.66			
9	500	2500	2.23	5.15			
10	500	2500	2.35	5.27			
11	500	2500	2.51	5.43	44	45.5	
12	500	2500	2.68	5.60			
13	500	2500	2.84	5.76			
14	400	1600	1.92	4.58			
15	400	1600	2.03	4.69	56	57.5	
16	400	1600	2.14	4.80			

TOLERANCE X. ±0.50 X.XXX ±0.15 X.X ±0.35 X.XX ±0.25 Angular ±5°		PART NO. 2015WRS-XP-XX-HF		朝貴電子股份有限公司 CKM ELECTRONICS CO., LTD.	
		DRAWING NO. C-2015WRS-XP-XX-HF		TITLE: 2.0mm PITCH RIGHT ANGLE SMT TYPE CONNECTOR	
DWG TYPE. Customer Drawing		APPROVED BY Ivan_Su 2022/03/21	CHECKED BY Deliang Li 2022/03/21	DRAWN BY Ryan 2022/03/21	PAGE 2 OF 2 SCALE 3 : 1
REV.		REVISION RECORD		REV. 1	

I	EC-22031157	Update drawing	Ryan	2022/03/21
H	EC-21070941	Modify14P15p16p,package quantity	Heimer	2021/06/30
REV.	ECN NO	REVISION RECORD	DRAW	DATE