

PROPOSAL

RoHS

HF

CUST INFORMATION.

PART NO. NA	DRAWING NO. NA	REV. NA
----------------	-------------------	------------

A

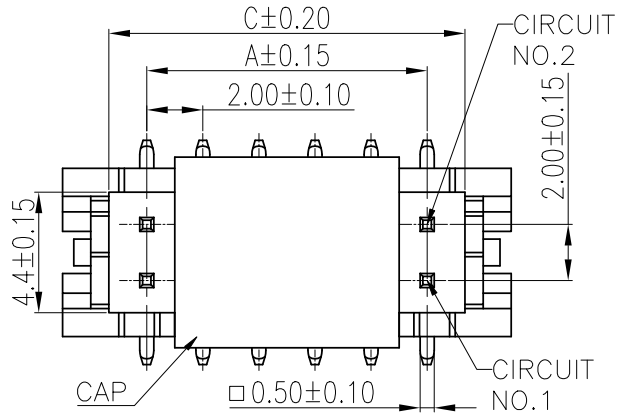

NOTE:

- MATERIAL: INSULATOR=NYLON 6T UL 94V-0(NATURAL)
CONTACT=SQ 0.50mm BRASS
 - FINISH: MATTE-TIN PLATED
 - RoHS & HF COMPLIANCE
 - BILL OF PART NO:
2008WSS-XX-AA-HK-HF
- No OF CIRCITS:06~40 _____ HF=HALOGEN FREE
- FOR AVAILABILITY, DELIVERY & MOQ, CONTACT CKM
 - DIMENSIONAL

B

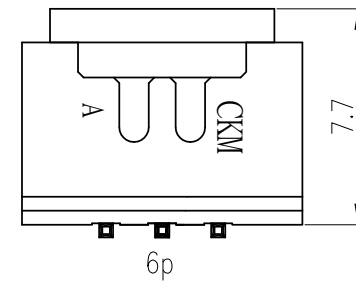
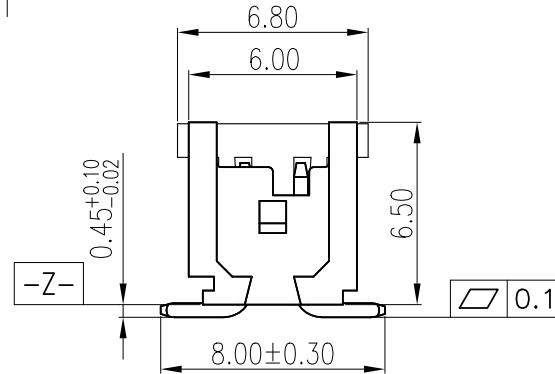
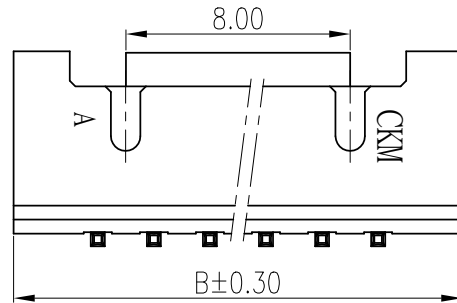

C

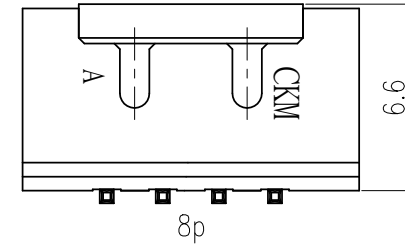
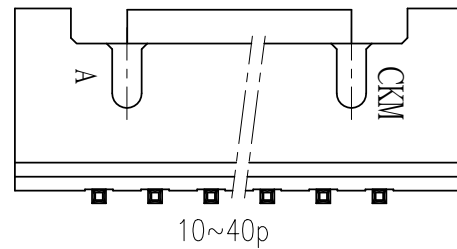
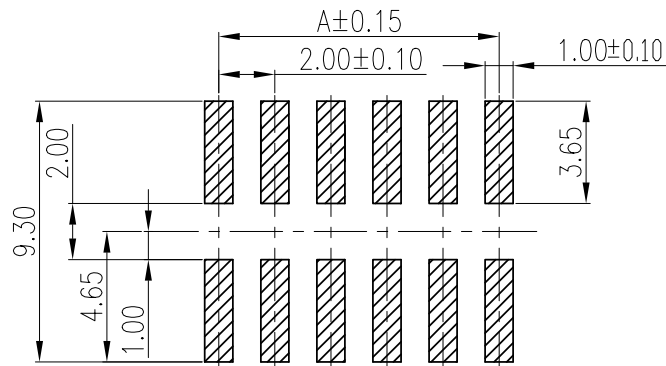

POS	A	B	C
06	4.0	10.0	6.7
08	6.0	12.0	8.7
10	8.0	14.0	10.7
12	10.0	16.0	12.7
14	12.0	18.0	14.7
16	14.0	20.0	16.7
18	16.0	22.0	18.7
20	18.0	24.0	20.7
22	20.0	26.0	22.7
24	22.0	28.0	24.7
26	24.0	30.0	26.7
28	26.0	32.0	28.7
30	28.0	34.0	30.7
32	30.0	36.0	32.7
34	32.0	38.0	34.7
36	34.0	40.0	36.7
38	36.0	42.0	38.7
40	38.0	44.0	40.7

D

RECOMMENDED PCB LAYOUT
T=1~1.6mm TOLERANCE: ±0.05

TOLERANCE X. X.XXX ±0.10 X.X ±0.30 X.XX ±0.20 Angular ±2°		PART NO. 2008WSS-XX-AA-HK-HF		朝貴電子股份有限公司 CKM ELECTRONICS CO., LTD.	
		DRAWING NO. C-2008WSS-XX-AA-HK-HF		TITLE. 2.0mm PITCH VERTICAL SMT TYPE CONNECTOR	
UNIT: mm		APPROVED BY Ivan Su 2021/12/18	CHECKED BY Deliang Li 2021/12/18	DRAWN BY Ryan 2021/12/18	PAGE 1 OF 2 SCALE 4 : 1
DWG TYPE. Customer Drawing		REV. C			

C	EC-21121080	RENEW THE DRAWING	Ryan	2021/12/18
B		ADD 36~40 Pin	JIMMY	2020/08/31
REV.	ECN NO	REVISION RECORD	DRAW	DATE

RoHS

HF

CUST INFORMATION.

PART NO. NA	DRAWING NO. NA	REV. NA
----------------	-------------------	------------

產品拉出方向

A

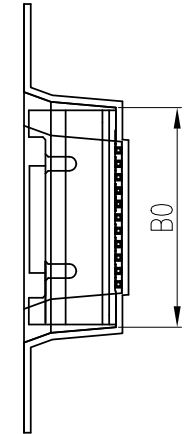
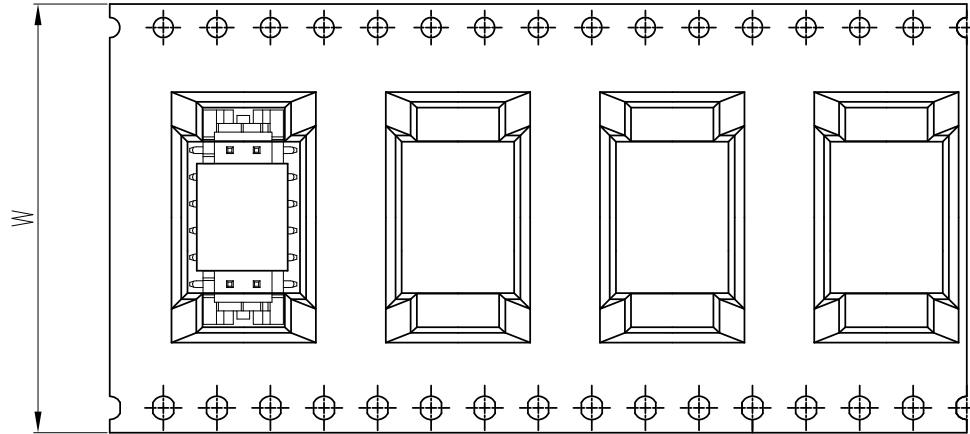
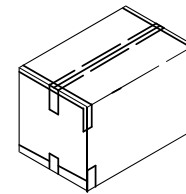
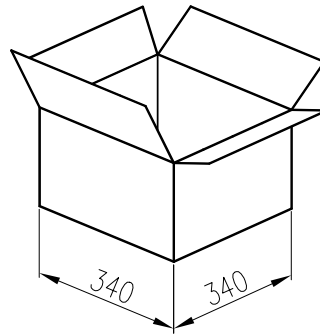
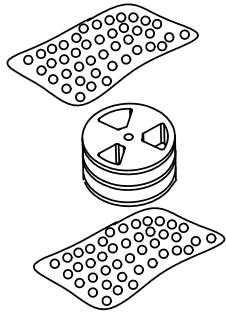
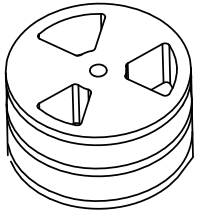
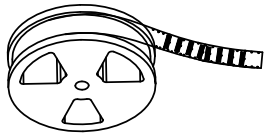
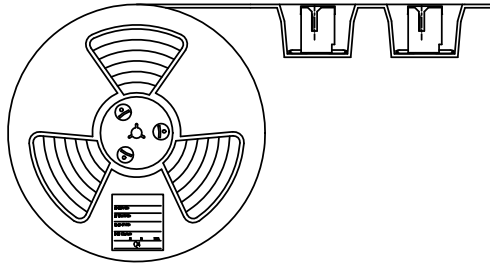

A

B

C

D

ORDERING INFORMATION

POS	W(mm)	PCS/REEL	PCS/CARTON
6	24	450	3150
8	24	450	3150
10	24	450	3150
12	32	550	2750
14	32	550	2750
16	44	550	2200
18	44	550	2200
20	44	550	2200
22	44	550	2200
24	44	550	2200
26	44	550	2200
28	56	550	1650
30	56	550	1650
32	56	550	1650
34	56	550	1650
36	56	550	1650
38	56	550	1650
40	72	550	1100

CKM
2021.12.22
研发部

TOLERANCE		PART NO.		朝貴電子股份有限公司 CKM ELECTRONICS CO., LTD.	
X.	X.XXX ±0.10	2008WSS-XX-AA-HK-HF			
X.X	±0.30	DRAWING NO.		TITLE.	
X.XX	±0.20	C-2008WSS-XX-AA-HK-HF		2.0mm PITCH VERTICAL SMT TYPE CONNECTOR	
UNIT: mm		APPROVED BY	CHECKED BY	DRAWN BY	PAGE
DWG TYPE.		Ivan Su	Deliang Li	Ryan	2 OF 2
Customer Drawing		2021/12/18	2021/12/18	2021/12/18	SCALE
				4 : 1	
				REV. C	

C	EC-21121080	RENEW THE DRAWING	Ryan	2021/12/18
B		ADD 36~40 Pin	JIMMY	2020/08/31
REV.	ECN NO	REVISION RECORD	DRAW	DATE