

RoHS

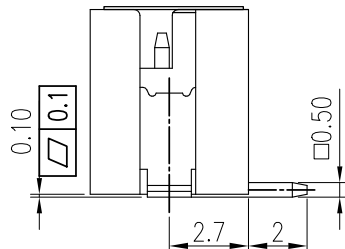

NOTE:

- MATERIAL:
 - 1.1 INSULATOR: LCP UL 94V-0 (NATURAL)
 - 1.2 CONTACT: SQ 0.50mm BRASS
 - 1.3 SOLDER TAB: THICK 0.20mm BRASS
- FINISH:
 - 2.1 CONTACT: MATTE TIN OR GOLD FLASH
 - 2.2 SOLDER TAB: BRIGHT TIN PLATING
- RoHS & HALOGEN-FREE COMPLIANCE
- BILL OF PART NO.:
 - 2001WVS-XP-X-LC-HF
 - FINISH: A=MATTE TIN PLATING
 - C=GOLD FLASH PLATING \triangle
 - NO OF CIRCUITS: 2~16
- FOR FINISH, AVAILABILITY, DELIVERY & MOQ, CONTACT CKM
- DIMENSIONAL \triangle

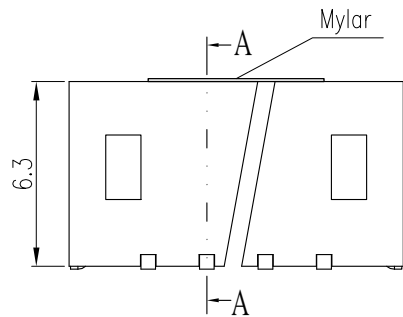
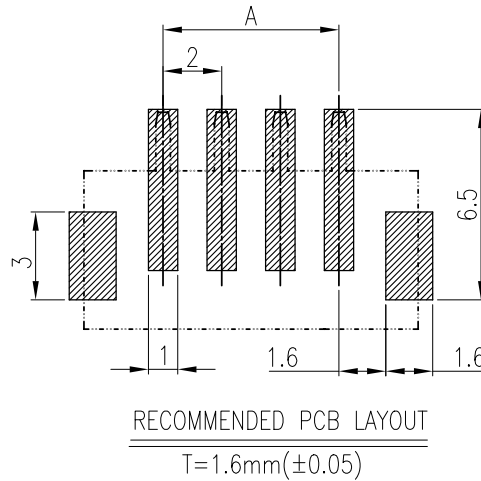
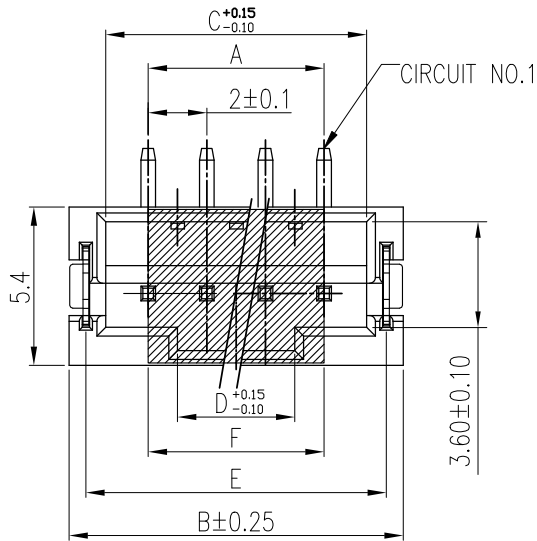

POS	A	B	C	D	E	F
2	2.00	7.40	4.90	0.60	6.25	7
3	4.00	9.40	6.90	2.00	8.25	
4	6.00	11.40	8.90	4.00	10.25	
5	8.00	13.40	10.90	6.00	12.25	
6	10.00	15.40	12.90	8.00	14.25	
7	12.00	17.40	14.90	10.00	16.25	17
8	14.00	19.40	16.90	12.00	18.25	
9	16.00	21.40	18.90	14.00	20.25	
10	18.00	23.40	20.90	16.00	22.25	
11	20.00	25.40	22.90	18.00	24.25	
12	22.00	27.40	24.90	20.00	26.25	27
13	24.00	29.40	26.90	22.00	28.25	
14	26.00	31.40	28.90	24.00	30.25	
15	28.00	33.40	30.90	26.00	32.25	
16	30.00	35.40	32.90	28.00	34.25	

TOLERANCE X. X.XXX ±0.10 X.X ±0.30 X.XX ±0.20 Angular ±2°		PART NO. 2001WVS-XP-A-LC-HF		朝貴電子股份有限公司 CKM ELECTRONICS CO., LTD.	
		DRAWING NO. C-2001WVS-XP-A-LC-HF		DESCRIPTION CKM 2001 SERIES 2.0mm PITCH VERTICAL SMT TYPE CONNECTOR	
DWG TYPE. Customer Drawing		APPROVED BY Ivan Su 2021/12/11	CHECKED BY Deliang Li 2021/12/11	DRAWN BY Ryan 2021/12/11	PAGE 1 OF 2 SCALE 4 : 1
				REV. E	

E	EC-21121082	RENEW THE DRAWING	Ryan	2021/12/11
D		ADD F DIM	Lance Cheng	2021/10/18
REV.	ECN NO	REVISION RECORD	DRAW	DATE

RoHS

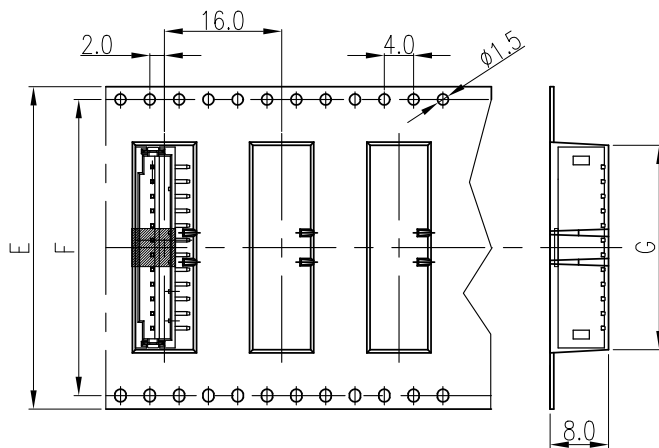
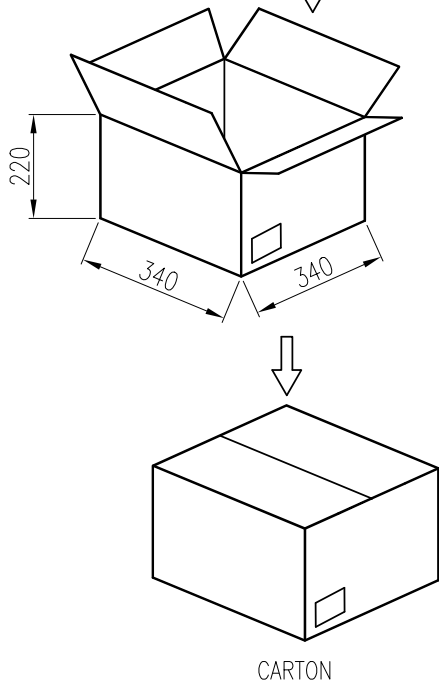
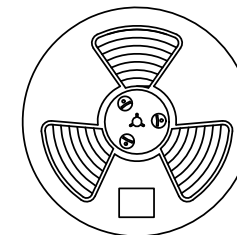
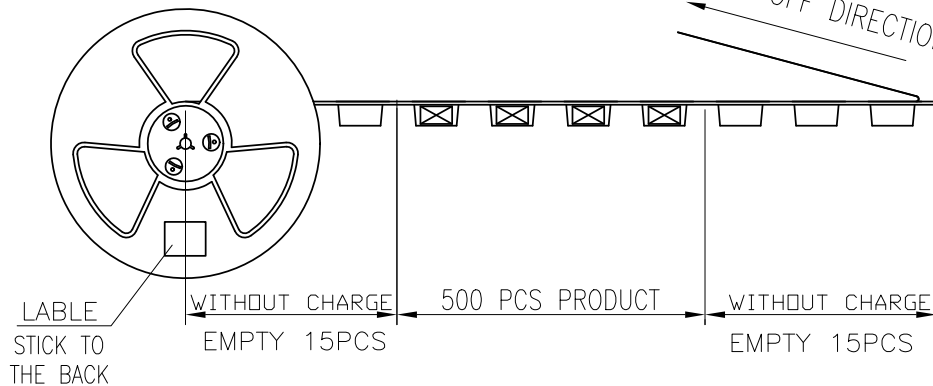
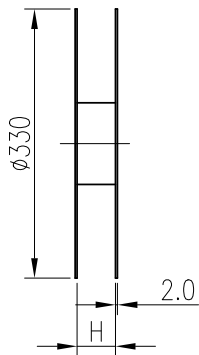
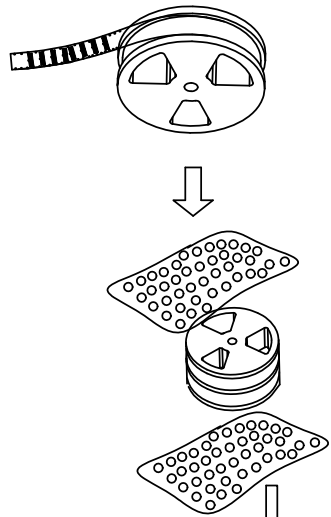

DIMENSIONAL & ORDERING INFORMATION

POS	E	F	G	H	PCS/REEL	PCS/CARTON
2					500	2500
3						2500
4	32.0	28.4	15.9	33.5		2500
5						2500
6						2500
7						2000
8						2000
9						2000
10	44.0	40.4	28.3	45.5		2000
11						2000
12						2000
13						1500
14	56.0	52.4	35.9	57.5		1500
15						1500
16						1500



TOLERANCE X. X.XXX ±0.10 X.X ±0.30 X.XX ±0.20 Angular ±2°		PART NO. 2001WVS-XP-A-LC-HF		朝貴電子股份有限公司 CKM ELECTRONICS CO., LTD.	
		DRAWING NO. C-2001WVS-XP-A-LC-HF		DESCRIPTION CKM 2001 SERIES 2.0mm PITCH VERTICAL SMT TYPE CONNECTOR	
UNIT: mm		APPROVED BY Ivan Su 2021/12/11	CHECKED BY Deliang Li 2021/12/11	DRAWN BY Ryan 2021/12/11	PAGE 2 OF 2 SCALE 4 : 1
DWG TYPE. Customer Drawing		REV. E			

E	EC-21121082	RENEW THE DRAWING	Ryan	2021/12/11
D		ADD F DIM	Lance Cheng	2021/10/18
REV.	ECN NO	REVISION RECORD	DRAW	DATE