

RoHS

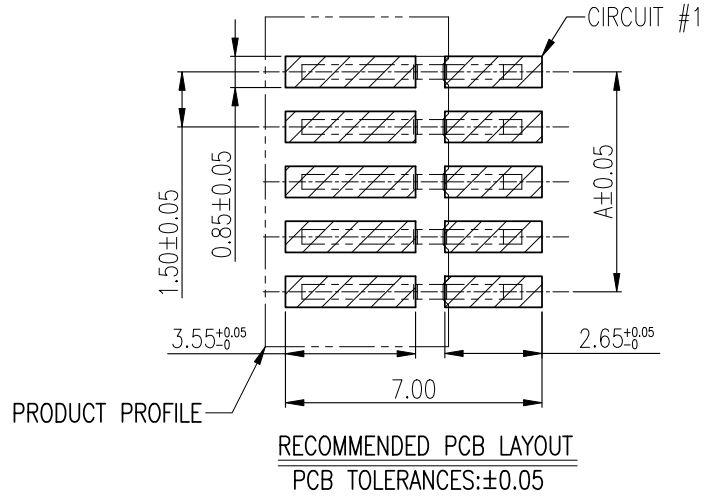
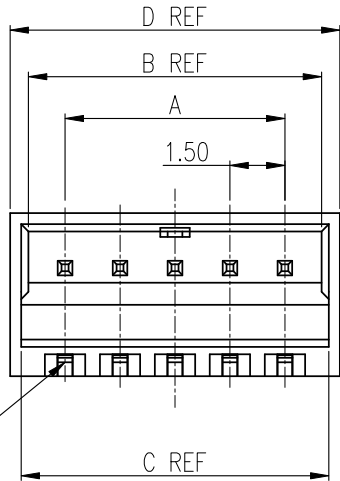

- NOTES:
- MATERIAL SPECIFICATION:
 - INSULATION: NYLON 9T, UL 94V-0.
 - CONTACT: THICK 0.40mm BRASS.
 - FINISH:
 - CONTACT: TIN/GOLD PLATED.
 - BILL OF PART NO:

1502WR-XXP-XX-XX

NO. OF CIRCUITS: 02~15

FINISH: _____

HSG MATERIAL: 9T: NYLON 9T
COLOR: BLACK(NATURAL)
A: BLACK
 - FOR COLOR, AVAILABILITY, DELIVERY & MOQ, CONTACT CKM.
 - DIMENSIONAL

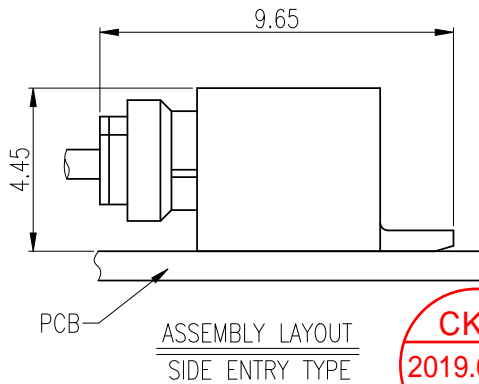
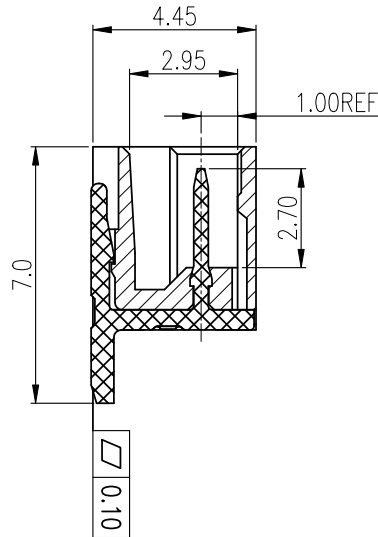
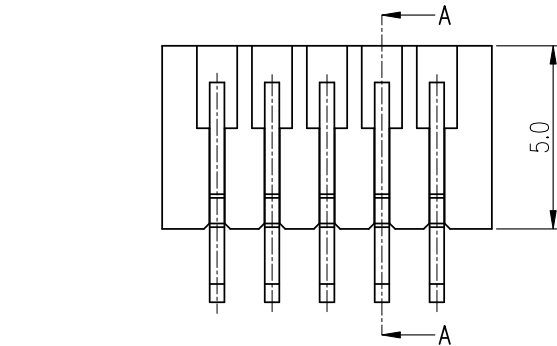

Pos.	A	B	C	D
2	1.5	3.5	3.9	4.5
3	3.0	5.0	5.4	6.0
4	4.5	6.5	6.9	7.5
5	6.0	8.0	8.4	9.0
6	7.5	9.5	9.9	10.5
7	9.0	11.0	11.4	12.0
8	10.5	12.5	12.9	13.5
9	12.0	14.0	14.4	15.0
10	13.5	15.5	15.9	16.5
11	15.0	17.0	17.4	18.0
12	16.5	18.5	18.9	19.5
13	18.0	20.0	20.4	21.0
14	19.5	21.5	21.9	22.5
15	21.0	23.0	23.4	24.0

CKM
2019.04.24
研发部

A		NEW RELEASE	Rock	2017.05.04
REV.	ECN NO	REVISION RECORD	DRAW	DATE

TOLERANCE X. X.XXX ±0.10 X.X ±0.30 X.XX ±0.20 Angular ±2°		PART NO. 1502WR-XXP-XX-XX		(CKM) 朝貴電子股份有限公司 CKM ELECTRONICS CO., LTD.	
UNIT: mm 		DRAWING NO. C-1502WR-XXP-XX-XX		DESCRIPTION 1.5mm PITCH RIGHT ANGLE SMT TYPE CONNECTOR	
DWG TYPE. Customer Drawing		APPROVED BY Angus.Chen 2017.05.04	CHECKED BY Angus.Chen 2017.05.04	DRAWN BY Rock 2017.05.04	PAGE 1 OF 2 SCALE 5 : 1
					REV. A

RoHS

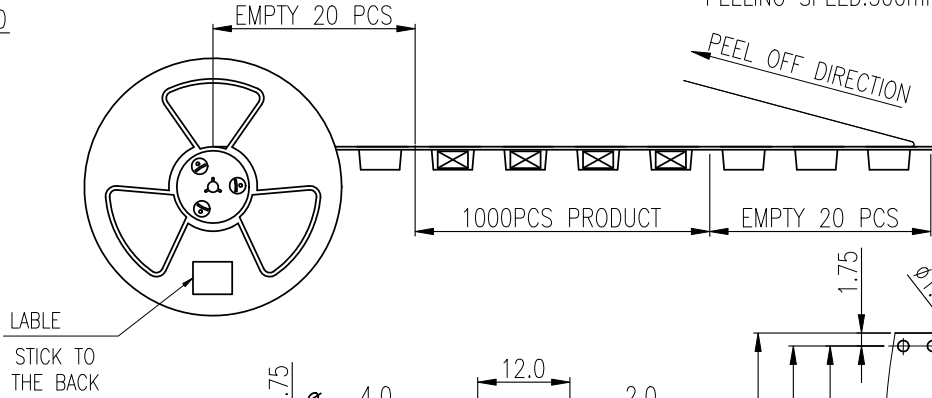
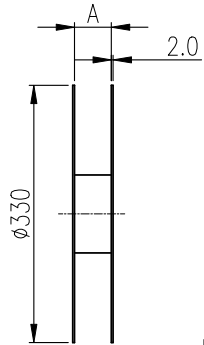

PEELING STRENGTH:10~130GF
PEELING SPEED:300mm/Min

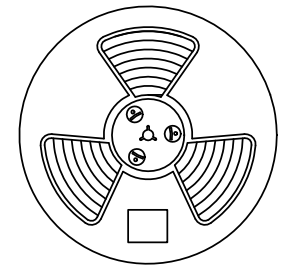

TABLE 2:

POS	PCS/REEL	PCS/CARTON	NET WEIGHT (KG)	CROSS WEIGHT (KG)
2	1000	9000	1.24	4.99
3	1000	9000	1.66	5.41
4	1000	9000	2.07	5.82
5	1000	6000	1.66	4.36
6	1000	6000	1.93	4.63
7	1000	6000	2.21	4.91
8	1000	6000	2.48	5.18
9	1000	6000	2.76	5.46
10	1000	4000	2.02	4.02
11	1000	4000	2.21	4.21
12	1000	4000	2.39	4.39
13	1000	4000	2.58	4.58
14	1000	4000	2.76	4.76
15	1000	4000	2.94	4.94

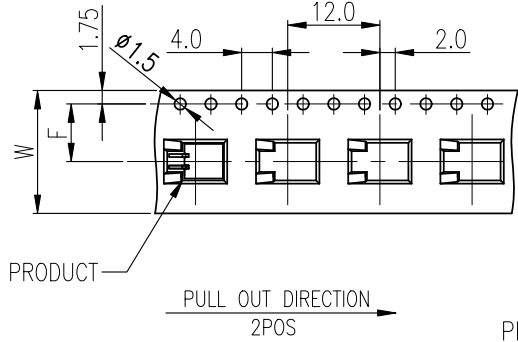
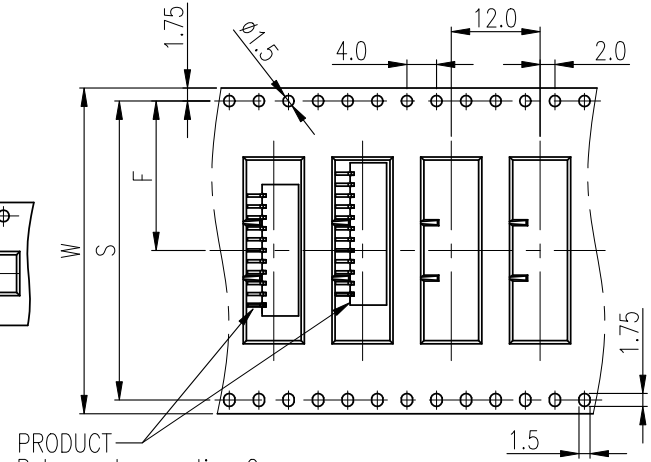
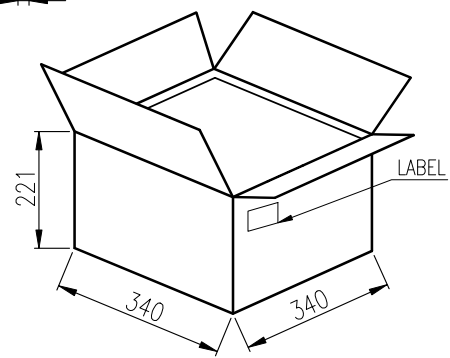
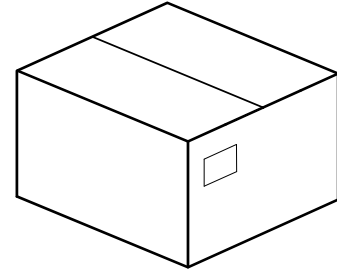

TABLE 1:

POS.	A	W	S	F
2	16.5	16.0	/	7.5
3~7	24.5	24.0	/	11.5
8~13	44.5	44.0	40.4	20.2
14~15	53.5	53.0	49.4	24.7



PRODUCT Between two parties Or lean against the top



CKM
2019.04.24
研发部

TOLERANCE X. X.XXX ±0.10 X.X ±0.30 X.XX ±0.20 Angular ±2°		PART NO. 1502WR-XXP-XX-XX		朝貴電子股份有限公司 CKM ELECTRONICS CO., LTD.	
UNIT: mm		DRAWING NO. C-1502WR-XXP-XX-XX		DESCRIPTION 1.5mm PITCH RIGHT ANGLE SMT TYPE CONNECTOR PACKING	
DWG TYPE. Customer Drawing		APPROVED BY Angus.Chen 2017.05.04	CHECKED BY Angus.Chen 2017.05.04	DRAWN BY Rock 2017.05.04	PAGE 2 OF 2 SCALE 5 : 1
				REV. A	

A		NEW RELEASE	Rock	2017.05.04
REV.	ECN NO	REVISION RECORD	DRAW	DATE