

RoHS

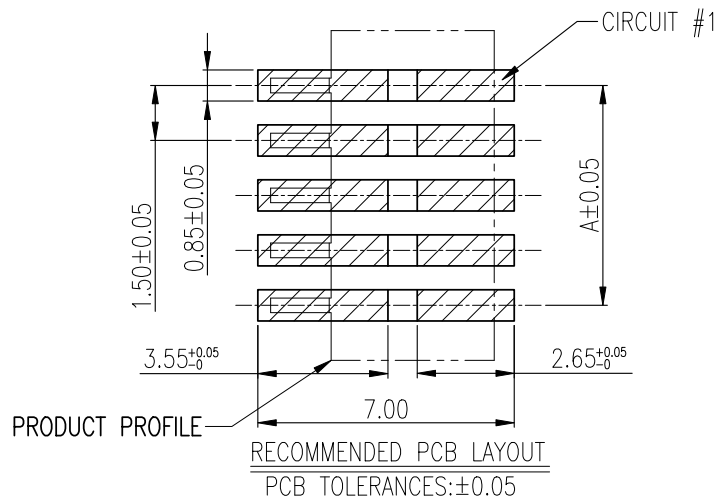
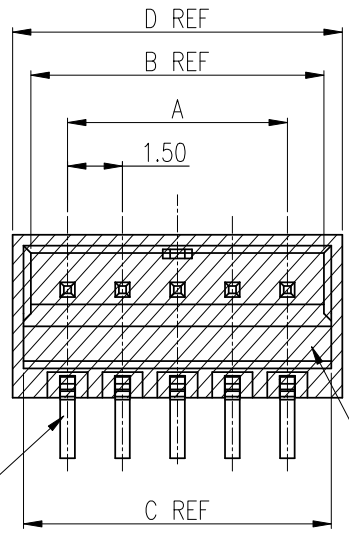

- NOTES:
- MATERIAL SPECIFICATION:
    - INSULATION: NYLON 9T, UL 94V-0.
    - CONTACT: THICK 0.40mm BRASS.
  - FINISH:
    - CONTACT: TIN/GOLD PLATED.
  - BILL OF PART NO:
 

1502WV-XXP-XX-XX

NO. OF CIRCUITS: 02~15

FINISH:

HSG MATERIAL: 9T: NYLON 9T  
COLOR: BLANK (NATURAL)  
A: BLACK
  - FOR COLOR, AVAILABILITY, DELIVERY & MOQ, CONTACT CKM.
  - DIMENSIONAL

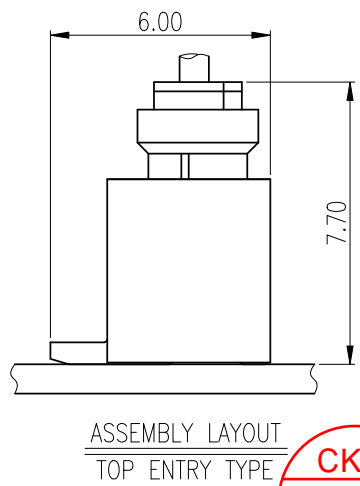
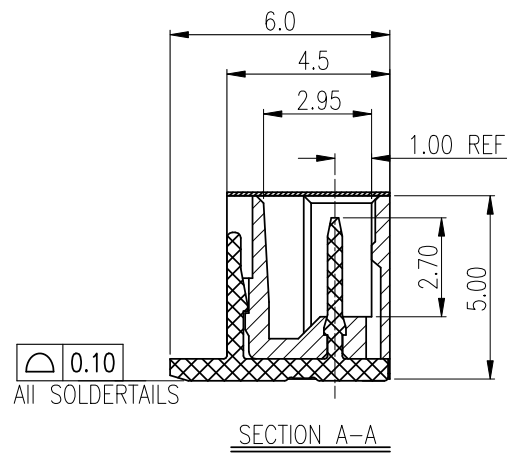
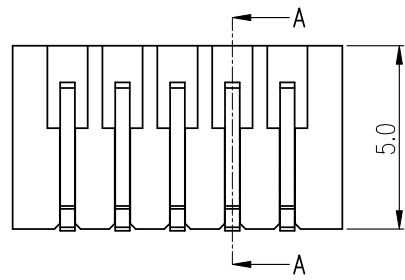

POS	A	B	C	D
2	1.5	3.5	3.9	4.5
3	3.0	5.0	5.4	6.0
4	4.5	6.5	6.9	7.5
5	6.0	8.0	8.4	9.0
6	7.5	9.5	9.9	10.5
7	9.0	11.0	11.4	12.0
8	10.5	12.5	12.9	13.5
9	12.0	14.0	14.4	15.0
10	13.5	15.5	15.9	16.5
11	15.0	17.0	17.4	18.0
12	16.5	18.5	18.9	19.5
13	18.0	20.0	20.4	21.0
14	19.5	21.5	21.9	22.5
15	21.0	23.0	23.4	24.0

CKM  
2019.04.23  
研发部

A		NEW RELEASE	Rock	2017.05.04
REV.	ECN NO	REVISION RECORD	DRAW	DATE

<b>TOLERANCE</b> X. X.XXX ±0.10 X.X ±0.30 X.XX ±0.20 Angular ±2°		<b>PART NO.</b> 1502WV-XXP-XX-XX		朝貴電子股份有限公司 CKM ELECTRONICS CO., LTD.	
<b>UNIT:</b> mm		<b>DRAWING NO.</b> C-1502WV-XXP-XX-XX		<b>DESCRIPTION</b> 1.5mm PITCH VERTICAL SMT TYPE CONNECTOR	
<b>DWG TYPE.</b> Customer Drawing		<b>APPROVED BY</b> Angus.Chen 2017.05.04	<b>CHECKED BY</b> Angus.Chen 2017.05.04	<b>DRAWN BY</b> Rock 2017.05.04	<b>PAGE</b> 1 OF 2  <b>SCALE</b> 5 : 1
					<b>REV.</b> A

# RoHS

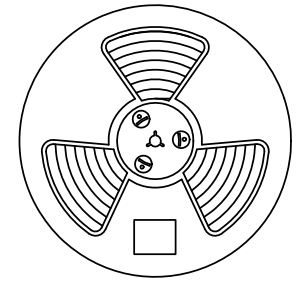
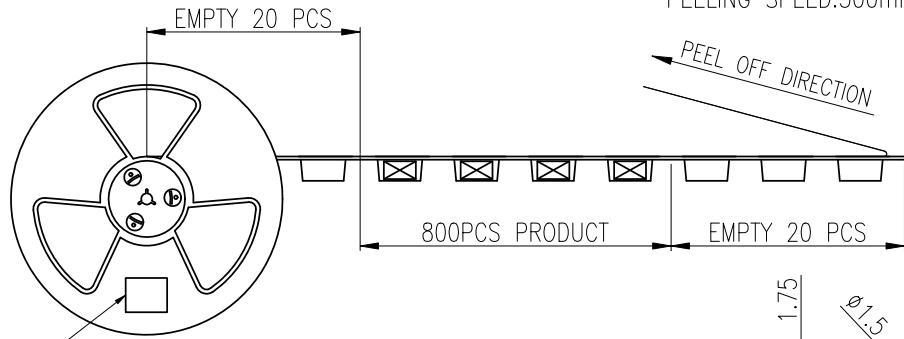
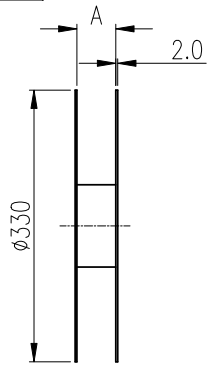

LABLE  
STICK TO  
THE BACK

PEELING STRENGTH:10~130GF  
PEELING SPEED:300mm/Min

TABLE 2:

POS	PCS/REEL	PCS/CARTON	NET WEIGHT (KG)	CROSS WEIGHT (KG)
2	800	7200	0.99	4.74
3	800	7200	1.32	5.07
4	800	7200	1.66	5.41
5	800	4800	1.32	4.02
6	800	4800	1.55	4.25
7	800	4800	1.77	4.47
8	800	4800	1.99	4.69
9	800	4800	2.21	4.91
10	800	3200	1.62	3.62
11	800	3200	1.77	3.77
12	800	3200	1.91	3.91
13	800	3200	2.06	4.06
14	800	3200	2.21	4.21
15	800	3200	2.36	4.36

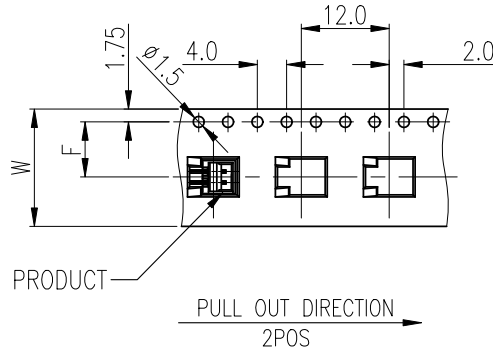
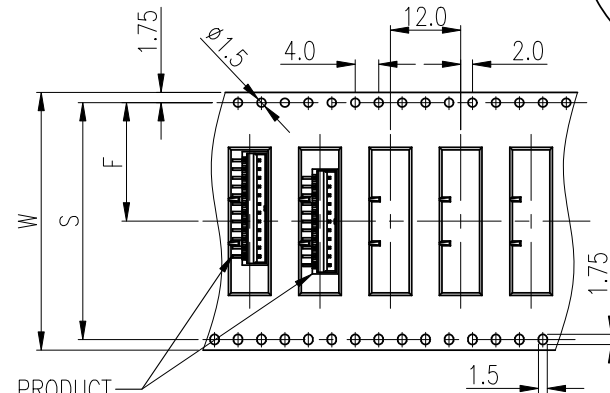
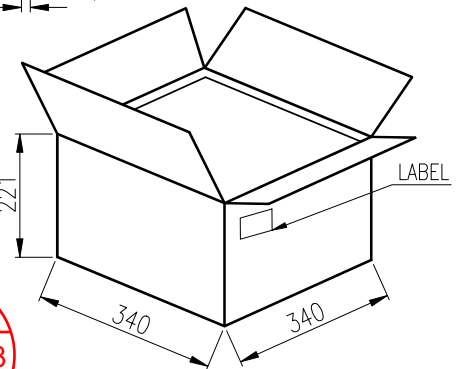
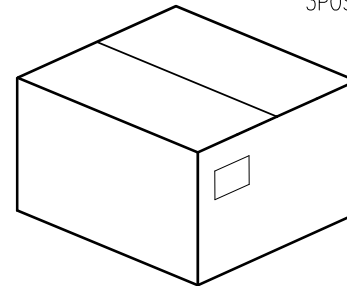

TABLE 1:

POS.	A	W	S	F
2~4	16.5	16.0	/	7.5
5~9	24.5	24.0	/	11.5
10~15	44.5	44.0	40.4	20.2



PRODUCT  
Between two parties Or  
lean against the top



**CKM**  
2019.04.23  
研发部

<b>TOLERANCE</b> X. XXX ±0.10 X.X ±0.30 X.XX ±0.20 Angular ±2°		<b>PART NO.</b> 1502WV-XXP-XX-XX		朝貴電子股份有限公司 CKM ELECTRONICS CO., LTD.	
		<b>DRAWING NO.</b> C-1502WV-XXP-XX-XX		<b>DESCRIPTION</b> 1.5mm PITCH VERTICAL SMT TYPE CONNECTOR PACKING	
<b>UNIT:</b> mm		<b>APPROVED BY</b> Angus.Chen 2017.05.04	<b>CHECKED BY</b> Angus.Chen 2017.05.04	<b>DRAWN BY</b> Rock 2017.05.04	<b>PAGE</b> 2 OF 2 <b>SCALE</b> 5 : 1
<b>DWG TYPE.</b> Customer Drawing				<b>REV.</b> A	

A		NEW RELEASE	Rock	2017.05.04
<b>REV.</b>	<b>ECN NO</b>	<b>REVISION RECORD</b>	<b>DRAW</b>	<b>DATE</b>