

RoHS

HF

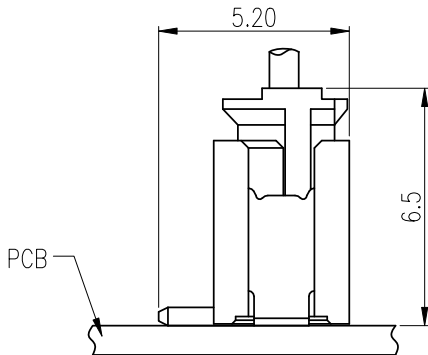
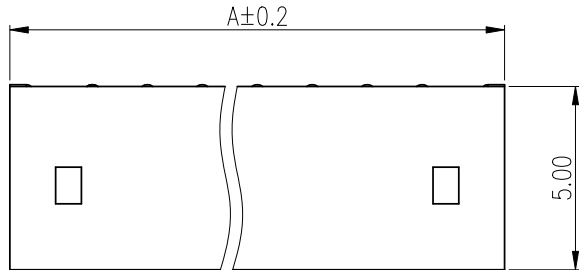

NOTE:

1. MATERIAL SPECIFICATION
 - 1.1.HSG: LCP UL94V-0.
 - 1.2.PIN: ϕ 0.5mm BRASS.
 - 1.3.SOLDER TAB: 0.2mm THICK BRASS .
2. PLATING SPECIFICATION
 - 2.1.PIN:MATTE TIN PLATED.
 - 2.2.SOLDER TAB:BRIGHT TIN PLATED.
- 3.BILL OF PART NO:

1501WVS-XP-AX-HF

NO OF CIRCUITS:2~15
 FINISH:A=MATTE TIN PLATING.
 HF=HALOGEN FREE
 COLOR CODE:SEE TABLE

4. FOR COLOR,AVAILABILITY,DELIVERY & MOQ,CONTACT CKM.
- 5 .DIMENSIONAL

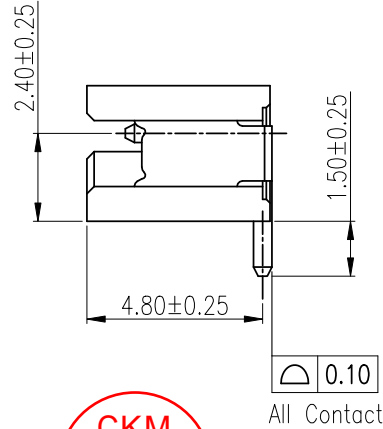
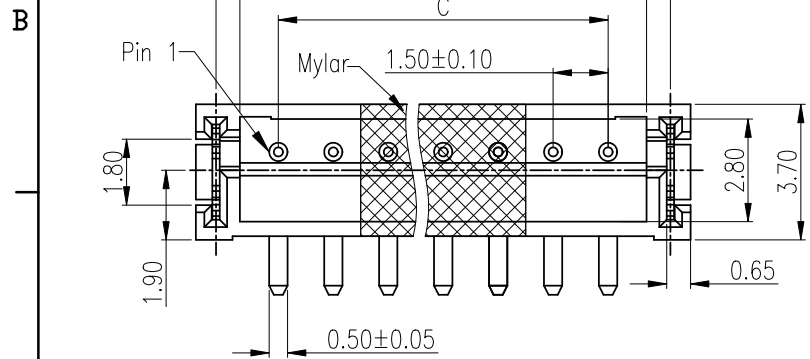

POS.	A	B	C	D
2	6.00	3.60	/	4.90
3	7.50	5.10	3.00	6.40
4	9.00	6.60	4.50	7.90
5	10.50	8.10	6.00	9.40
6	12.00	9.60	7.50	10.90
7	13.50	11.10	9.00	12.40
8	15.00	12.60	10.50	13.90
9	16.50	14.10	12.00	15.40
10	18.00	15.60	13.50	16.90
11	19.50	17.10	15.00	18.40
12	21.00	18.60	16.50	19.90
13	22.50	20.10	18.00	21.40
14	24.00	21.60	19.50	22.90
15	25.50	23.10	21.00	24.40

COLOR CODE	
BLANK	NATURAL
A	BLACK
C	RED
G	BLUE

CKM
2019.03.25
研发部

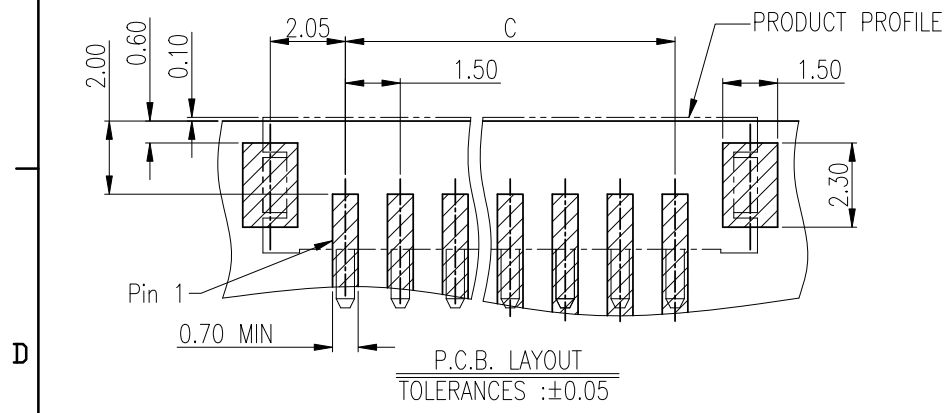

TOLERANCE		PART NO.		朝貴電子股份有限公司 CKM ELECTRONICS CO., LTD.	
X. X.XXX ±0.10	X.X ±0.30	1501WVS-XP-AX-HF			
X.XX ±0.20	Angular ±2°	DRAWING NO.		DESCRIPTION	
UNIT: mm Customer Drawing		C-1501WVS-XP-AX-HF		WTB 1501 SERIES 1.50mm PITCH VERTICAL SMT TYPE	
APPROVED BY	CHECKED BY	DRAWN BY	PAGE	REV.	
Angus.Chen	Sun.Lee	Rock	1 OF 2	B	
2019.02.27	2019.02.27	2019.02.27	SCALE		
			5 : 1		

B	EC-19020199	UPGRADE DRAWING	Rock	2019.02.27
A		NEW RELEASE	Rock	2017.04.07
REV.	ECN NO	REVISION RECORD	DRAW	DATE

RoHS

HF

PEELING STRENGTH: 10~130GF
PEELING SPEED: 300mm/Min

CKM
2019.03.25
研发部

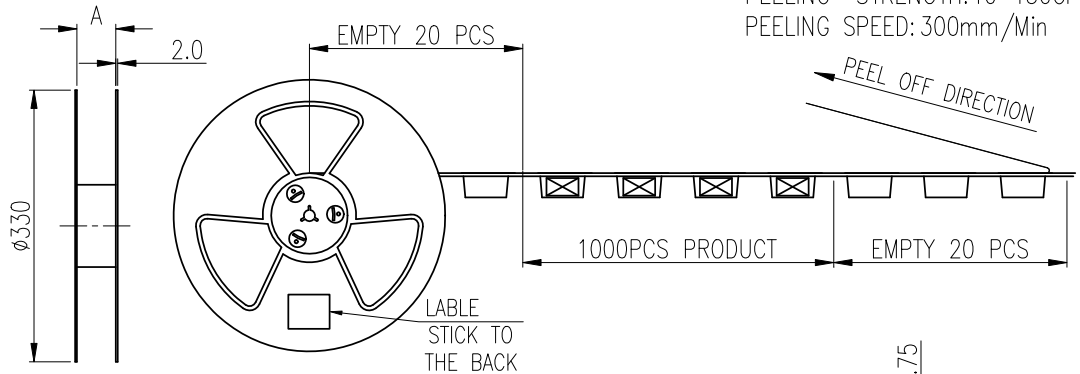

TABLE 1:

POS.	A	W	S	F
2	16.5	16.0		7.5
3~7	24.5	24.0		11.5
8~13	44.5	44.0	40.4	20.2
14~15	53.5	53.0	49.4	24.7

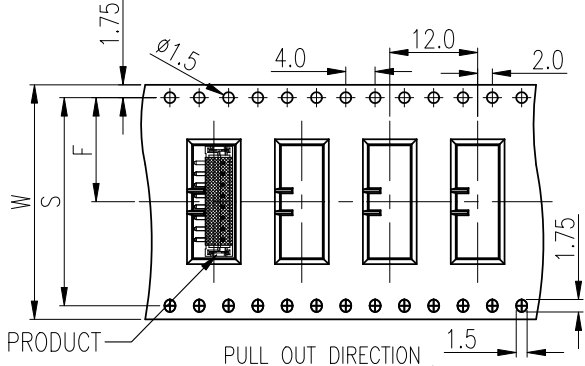
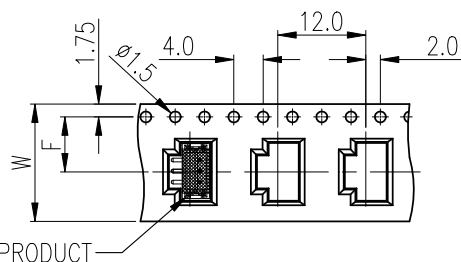
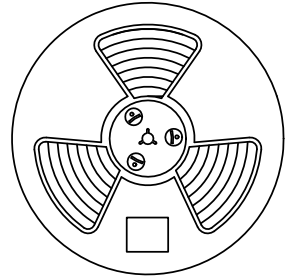
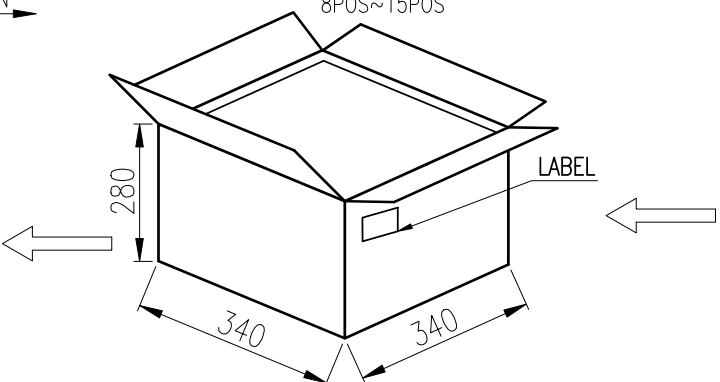
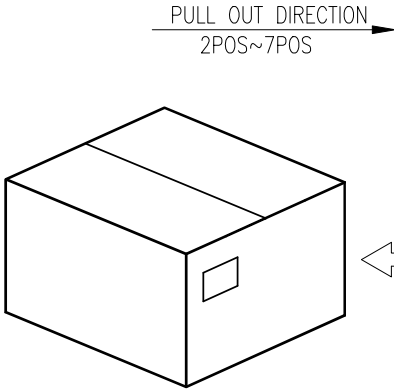

TABLE 2:

POS	PCS/REEL	PCS/CARTON	NET WEIGHT (KG)	CROSS WEIGHT (KG)
2	1000	9000	1.80	4.97
3	1000	9000	2.16	5.33
4	1000	5000	1.41	4.09
5	1000	5000	1.62	4.30
6	1000	5000	1.83	4.51
7	1000	5000	2.03	4.71
8	1000	5000	2.24	4.92
9	1000	5000	2.44	5.12
10	1000	4000	2.12	4.69
11	1000	4000	2.28	4.85
12	1000	4000	2.45	5.02
13	1000	4000	2.62	5.19
14	1000	4000	2.78	5.35
15	1000	4000	2.94	5.51



TOLERANCE X. X.XXX ±0.10 X.X ±0.30 X.XX ±0.20 Angular ±2°		PART NO. 1501WVS-XP-AX-HF		朝貴電子股份有限公司 CKM ELECTRONICS CO., LTD.	
UNIT: mm		DRAWING NO. C-1501WVS-XP-AX-HF		DESCRIPTION WTB 1501 SERIES 1.50mm PITCH VERTICAL SMT TYPE PACKING	
DWG TYPE. Customer Drawing		APPROVED BY Angus.Chen 2019.02.27	CHECKED BY Sun.Lee 2019.02.27	DRAWN BY Rock 2019.02.27	PAGE 2 OF 2 SCALE 5 : 1
				REV. B	

B	EC-19020199	UPGRADE DRAWING	Rock	2019.02.27
A		NEW RELEASE	Rock	2017.04.07
REV.	ECN NO	REVISION RECORD	DRAW	DATE