

RoHS

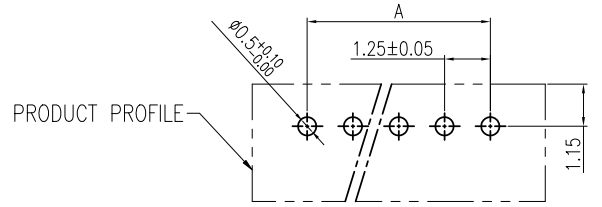

P.C. BOARD LAYOUT
(PCB THICK=0.8)
TOLERANCES ARE NON-CUMULATIVE:±0.05

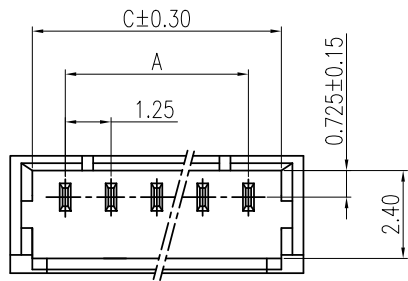
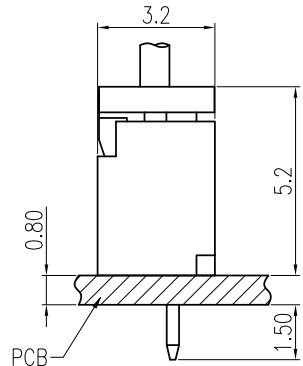
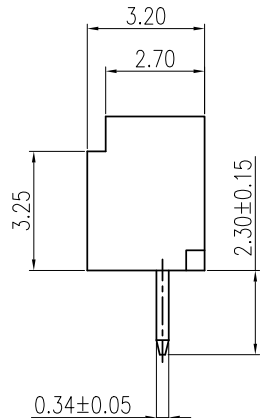
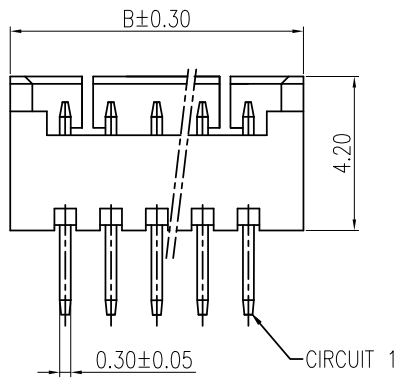

ASSEMBLY LAYOUT
TOP ENTRY TYPE

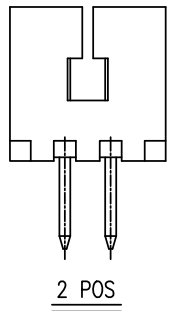

2 POS

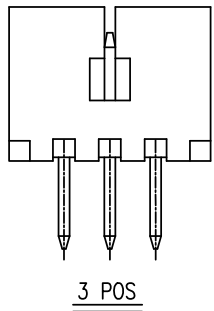

3 POS

NOTE:

- MATERIAL SPECIFICATION:
 - INSULATION: LCP UL 94V-0.
 - CONTACT: THICK 0.3mm PHOSPHOR BRONZE.

- FINISH SPECIFICATION:
 - CONTACT: TIN/GOLD PLATED

3. RoHS & HF COMPLIANCE

4. BILL OF PART NO:
1253WV-XP-X X-XXX-HF

NO. OF CIRCUITS: 2~15
FINISH
A=MATTE TIN PLATED
B=BRIGHT TIN PLATED
C=GOLD FLASH PLATED

HF=HALOGEN FREE
VOID CIRCUITS:BLANK=STANDARD OR 1~3 ALPHANUMERIC DIGITS
COLOR: BLANK(NATURAL) OR A~Z

- FOR COLOR, AVAILABILITY, DELIVERY & MOQ, CONTACT CKM
- DIMENSIONAL

POS	A	B	C
2		4.25	3.05
3	2.50	5.50	4.30
4	3.75	6.75	5.55
5	5.00	8.00	6.80
6	6.25	9.25	8.05
7	7.50	10.50	9.30
8	8.75	11.75	10.55
9	10.00	13.00	12.80
10	11.25	14.25	14.05
11	12.50	15.50	15.30
12	13.75	16.75	16.55
13	15.00	18.00	17.80
14	16.25	19.25	19.05
15	17.50	20.50	20.50



TOLERANCE		PART NO.		朝貴電子股份有限公司 CKM ELECTRONICS CO., LTD.	
X. X.X ±0.30	X.XXX ±0.10	1253WV-XP-XX-XXX-HF			
X.XX ±0.20	Angular ±2°	DRAWING NO.		DESCRIPTION	
UNIT: mm		C-125102X5-XXHF		CKM1253WV SERIES 1.25mm PITCH VERTICAL DIP TYPE CONNECTOR	
DWG TYPE.		APPROVED BY	CHECKED BY	DRAWN BY	PAGE
Customer Drawing		Ivan.Su 2022.05.23	Sun.Lee 2022.05.23	Rock 2022.05.23	1 OF 2
				SCALE	REV.
				5 : 1	C

C	EC-22050072	UPGRADE DESCRIPTION	Rock	2022.05.23
B		ADDS PACKING DIAGRAM	Rock	2016.12.30
REV.	ECN NO	REVISION RECORD	DRAW	DATE

RoHS

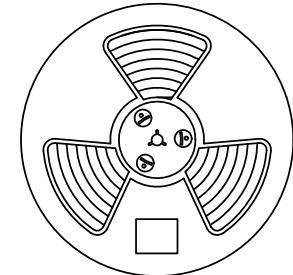
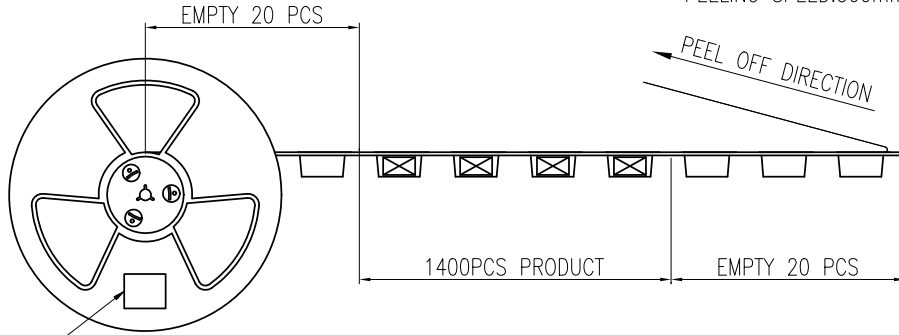
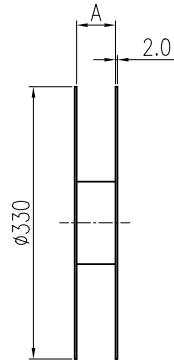

LABEL
STICK TO
THE BACK

TABLE 2:

POS	PCS/REEL	PCS/CARTON	NET WEIGHT (KG)	CROSS WEIGHT (KG)
2	1400	4200	0.19	2.39
3	1400	4200	0.24	2.47
4	1400	4200	0.30	2.54
5	1400	4200	0.35	2.62
6	1400	4200	0.41	2.70
7	1400	4200	0.46	2.77
8	1400	4200	0.51	2.85
9	1400	4200	0.57	3.40
10	1400	4200	0.62	3.48
11	1400	4200	0.68	3.56
12	1400	4200	0.73	3.63
13	1400	4200	0.78	3.71
14	1400	4200	0.84	3.78
15	1400	4200	0.89	3.86

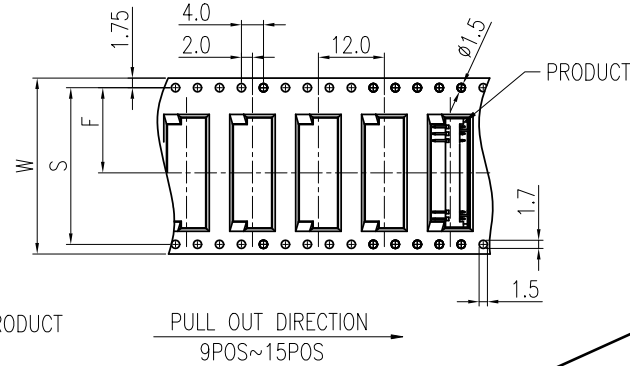
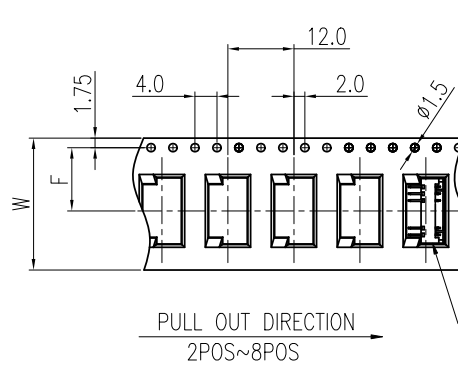
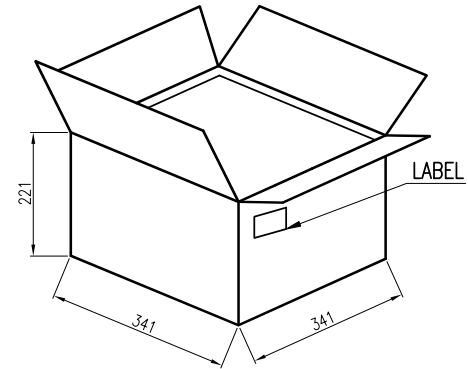
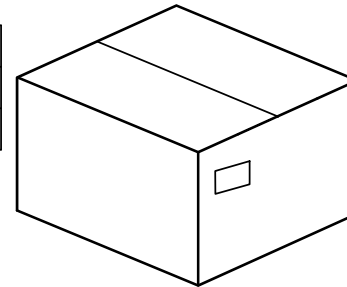

TABLE 1:

POS.	A	W	S	F	H
2~8	24.5	24.0		11.5	120
9~15	32.5	32.0	28.4	14.2	145



TOLERANCE		PART NO.		朝貴電子股份有限公司 CKM ELECTRONICS CO., LTD.	
X. X.X ±0.30	X.XXX ±0.10	1253WV-XP-XX-XXX-HF			
X.XX ±0.20	Angular ±2°	DRAWING NO.		DESCRIPTION	
UNIT: mm DWG TYPE: Customer Drawing		C-125102X5-XXHF		CKM1253WV SERIES 1.25mm PITCH VERTICAL DIP TYPE CONNECTOR	
APPROVED BY		CHECKED BY		DRAWN BY	
Ivan.Su 2022.05.23		Sun.Lee 2022.05.23		Rock 2022.05.23	
				PAGE	
				2 OF 2	
				SCALE	
				5 : 1	
				REV.	
				C	

C	EC-22050072	UPGRADE DESCRIPTION	Rock	2022.05.23
B		ADDS PACKING DIAGRAM	Rock	2016.12.30
REV.	ECN NO	REVISION RECORD	DRAW	DATE